

Tumble Heat Pump  
Dryer  
Model: CTT3801V

# Service Manual

## **Note:**

---

**Before service the unit, please read this manual first.  
Contact with your service center if meet problem**

# Contents

<b>1. PRECAUTION.....</b>	
1.1 SAFETY PRECAUTION	
1.2 Servicing Precautions	
1.3 CAUTIONS FOR SAFETY	
<b>2. FACTORY PATTERN DETECTION .....</b>	
<b>3. UNPACKING WAYS OF MAIN PARTS .....</b>	
3.1 Common questions when disassembling the machine	
3.2 Methods of disassembling the main subassemblies	
<b>4. MALFUNCTIONS CODES AND EXPLANATIONS .....</b>	
4.1 Condensing dryer alarm code	
<b>5. TROUBLESHOOTING .....</b>	
5.1 The dryer breaks down and the control panel can not display	
5.2 The drum does not spin but the control panel can display	
5.3 The heating system does not work	
5.4 The Dryer Marks Abnormal Noise When Operating	
5.5 The Dryer Gives Out Abnormal Smell When Operating	
5.6 Dryer Work LED Screen Shows Tank	
5.7 Heat Pump System Parts Repair	
<b>6. CHECK POINT OF CIRCUIT.....</b>	
<b>7. Service tools .....</b>	
<b>8. APPENDIX.....</b>	

# 1 Precaution

---

When performing troubleshooting and part replacement during servicing, note the following safety precautions:

## §1.1 Safety Precautions

### 1-1-1. Use Genuine Parts

The components of the washing machine have safety features such as non-combustibility and voltage withstanding. Therefore, always use the same part as suggested by the maker. In particular, be sure to use only designated parts in case of major safety parts identified by the marker.

### 1-1-2. Grounding

Connect the grounding wire to the shell plate, and bury it under at least 25cm of earth : alternatively, connect the ground wire to the appropriate pin on a properly grounded power receptacle. Never connect the wire to a telephone line, lightning rod, or gas pipe.

# 1 Precaution

---

## §1.2 Servicing Precautions

### 1-2-1. Observe Warnings

Be sure to follow special warning and precautions that are described on part labels and in the owner's manual.

### 1-2-2. Parts Assembly and Wiring

Be sure to use insulation material (such as tube and tape). And be sure to restore all parts and wires to their original position. Take special care to avoid contact with sharp edges.

### 1-2-3. Perform Safety Checks after Servicing

After servicing, check to see that the screws, parts, and wiring are restored to their original positions, and check the insulation between the external metals and the socket plug. In addition, place the washing machine in a level position (less than 1(one) degree) to prevent vibration and noise during operations.



### 1-2-4. Insulation Checks



Pull out the plug from the power receptacle, pour water into the spin tub, and then set the timer. Check to see that the resistance insulation between the terminals of the plug and the externally exposed metal is greater than 1M• .

**Note** :When it is impossible to perform insulation check with a 500V insulation resistance tester, use other testers for inspection.

## §1.3 CAUTIONS FOR SAFETY

- Please observe the following notes for safety.
- The symbols indicate as follows.

Symbol	Meaning
 <b>WARNING</b>	Indicates possibility of death or serious injury of a repair technician and a person nearby through the misconducted work, or of a user by a defect of the product after the work performed by the technician.
 <b>CAUTION</b>	Indicates possibility of injury or physical damages* of a repair technician and a person nearby through the misconducted work, or of a user by a defect of the product after the work performed by the technician.

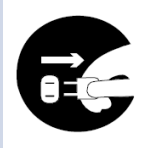
Graphic Symbol	Meaning
 <b>ELECTRIC SHOCK</b>	<ul style="list-style-type: none"><li>• indicates a caution (including a warning). Specific instruction is followed by a graphic or characters in or near Symbol left warns an electric shock.</li></ul>
 <b>DO NOT DISASSEMBLE</b>	<ul style="list-style-type: none"><li>• indicates prohibition (act must not be conducted). Specific instruction is followed by a graphic or characters in or near. Symbol left warns not to disassemble.</li></ul>
 <b>UNPLUG POWER</b>	<ul style="list-style-type: none"><li>• indicates forcing (act must be conducted). Specific instruction is followed by a graphic or characters in or near. Symbol left warns to unplug the power cord.</li></ul>

## §1.3 CAUTIONS FOR SAFETY

- Please observe the following notes for safety.
- The symbols indicate as follows.



### WARNING



#### OUT OF CHILD

- Advise the customer to keep children out of the work place. Children may be injured with a tool or a disassembled part.

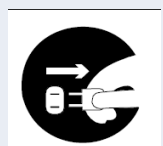

#### UNPLUG POWER

- Unplug power cord for the work such as disassembling which is not unnecessary to power on . Do not hold the plug by a wet hand.  
Failing to unplug may cause an electric shock.



#### USE REPAIR PARTS

- Use the specified repair parts when repairing the product. Otherwise, a malfunction or a defect may occur. Also, a short circuit, ignition or other danger to the customer may occur.



#### CHECK INSULATION RESISTANCE

- After repair, measure insulation resistance between the charging part (power cord plug) and the non-charging metallic part (ground) with an insulation resistance meter (500V). The resistance shall be 10M• or more.  
Failing to check the insulation resistance may cause a short circuit, electric shock or other diseases to the customer.



#### DO NOT MODIFY

- Do not modify the product.  
An electric shock or ignition may occur.



#### DO NOT DISASSEMBLE AND REPAIR

- Only a repair technician can disassemble and repair.  
An electric shock, ignition or malfunction may cause injury.

## §1.3 CAUTIONS FOR SAFETY



### WARNING



#### USE EXCLUSIVE SOCKET

- Use an exclusive A socket for the washing machine. Otherwise, an electric shock or ignition may cause. Sharing the same socket with other instrument causes heating of a branch socket and result in a fire.

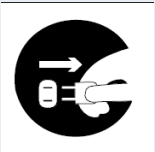

#### CONNECT GROUNDING WIRE

- Unplug power cord for the work such as disassembling which is not unnecessary to power on . Do not hold the plug by a wet hand. Failing to unplug may cause an electric shock.

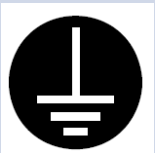

#### CONNECT GROUNDING WIRE

- Connect the grounding wire. Failing to do so may cause an electric shock when a short circuit occurs. Consult an electric work shop or a sales shop.



#### DO NOT USE WET PLACE

- Do not install in a bath room or a place exposed to wind or rain. An electric shock or a short circuit may cause a fire.

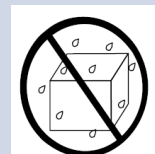

#### DO NOT SPLASH WATER

- Do not pour or immerse electrical parts into water or liquid solution. An electric shock or ignition may occur.



#### REMOVE DUST

- Wipe off dust adhered to the plug of power cord. Dust may cause a fire.

## §1.3 CAUTIONS FOR SAFETY



### WARNING



#### AVOID INFLAMMABLE

- Do not put inflammable into the washing tub. Do not put cloths stained with kerosene, gasoline, benzene, thinner, alcohol, etc. It may cause a fire or explosion.



#### CONNECT GROUNDING WIRE

- Do not touch the laundry before the spin basket stops completely. The laundry entangles your hand causing an injury even if the basket rotates slowly. Pay special attention to children.



### CAUTION



#### INSTALL CAREFULLY

- Ask an electric work shop to install the product. Install the product securely and safely according to the electrical equipment technical standard and the wiring standard. Incorrect work causes an electric shock and a fire.



#### DO NOT PULL

- Do not pull the power cord when unplugging. Hold the power plug to unplug. An electric shock or short circuit may cause a fire.

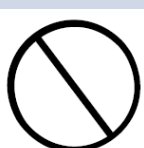

#### DANGER HAND

- Do not insert your hand under the washing machine during operation. There is a rotary part under the machine which may cause an injury.



#### WATER LEAKAGE

- Before starting washing, open the faucet and check water supply hose joint which shall not be loosened for no water leaks. The loose screw or hose joint may cause water leakage resulting in an unexpected damage.



## 2 Factory Pattern Detection

---



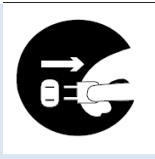

When the repairing work is done, select the "Time" programme to operate the dryer for at least 10 minutes. During this time, check if the dryer the tumble turning right and there is no undesired noise. After the programme is done, open the door, use your hand to check the tumble. If the tumble is warm, that means the dryer operates well.

# WARNING







**UNPLUG POWER**





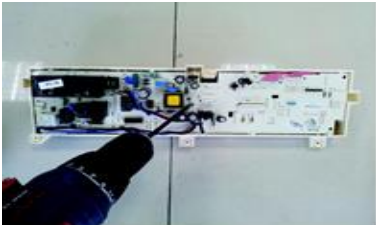



- Unplug power cord for the work such as disassembling which is not unnecessary to power on . Do not hold the plug by a wet hand.  
Failing to unplug may cause an electric shock.

ITEM	PICTURE
Unfasten the two screws behind the top panel with cross screwdriver and take it out backwards for taking	
Remove Water container_sub	
Remove 4 screws on the top	
Remove 2 screws inside the slot of the control panel	









# 3 Unpacking Ways Of Main Parts

ITEM	PICTURE
Pull out all connection pin behind the Control_panel_sub	
Remove Control_panel_sub	
Remove power panel sub	
Remove 1 screw on the power panel	
Push the tab in order to take of the power panel	
The power panel and the box of the power panel	







### 3 Unpacking Ways Of Main Parts

ITEM	PICTURE
Pull out the knob cover	
The central panel	
Remove the 2 screws on the door hinge	
Remove 6 screws on the inner ring	
Remove the inner ring	
Take off the door plunger	
Take off the door window	
Remove the protect cover	

### 3 Unpacking Ways Of Main Parts



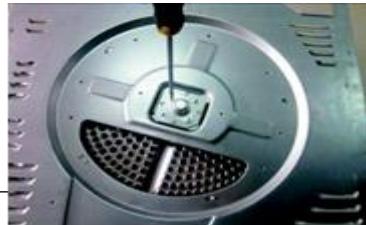



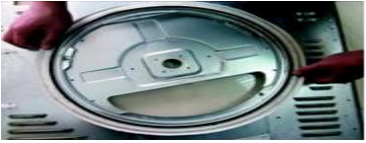

ITEM	PICTURE
Remove 2 screws	
Remove the door seal	
Remove 1 screws on the left of the front panel	
Remove 3 screws on the top	
Remove all of the screws on the Rear cover	
Remove 6 screws on the bottom of left_ side board	
Remove 4 screws on the side bracket	
Pull out the drain pipe	

# 3 Unpacking Ways Of Main Parts









ITEM	PICTURE
<p>The 7 filter assembly: Unplug the wire terminal filter, remove two screws on the connecting plate filters to remove the filter from the right Pulling in motor, capacitance, water pump on the plug wire terminal, and dismantle connection card buckle</p>	
<p>Press machine make spring compression, the pulley from motor</p>	
<p>Separate the Tub assembly</p>	
<p>Remove the power line</p>	
<p>Remove bearing cover screws to remove it</p>	
<p>Using a wrench will bearing assembly screws on the demolition, in turn, remove gasket and bearing components, back panel</p>	
<p>Remove 1 screws on the rear panel</p>	



# 3 Unpacking Ways Of Main Parts









ITEM	PICTURE
Counterclockwise rotation will be felt the fastening ring off	
Remove the screw barrel	
Remove the lifting rib	
Remove the connection pin	
Remove the fan	
Contrarotate the Impeller	
Remove 2 screws of the motor support	
Remove the motor	
Pull out the drain hose and overflow tube	

# 3 Unpacking Ways Of Main Parts

ITEM	PICTURE
Pull out the 2 pins of the drain pump	
Contrarotate the water-level sensor	
Take off the drain pump	
Contrarotate the capacitor	
Capacitor	
Unscrew the nut tool with protective sleeve	
Remove the protective sleeve	
Pull plug wire can be starter from compression	
Use a screwdriver to unscrew the grounding screw	





### 3 Unpacking Ways Of Main Parts

ITEM	PICTURE
Use a Phillips screwdriver to remove the 1 screws of the supporting the front	
Remove the filter cover, and take out the filter	
Remove the fan cover	
Remove 5 screws on the lower part of front door	
Pull out the connection pin of the switch	
The front support equipment to take off, and then removed before the door in front of all the screws, pull out the plug and switch on the plug wire and a temperature sensor on the front door take off	
Extraction of lights on the plug wire, the lamp rotary unloading	
Remove the 2 screws on the lower humidity sensor assembly ( in the state, from the inner cylinder inner roundabout removal of the screws can be)	
The humidity sensor apart, the back of the plug wire extraction and remove	

# 4 Malfunctions Codes And Explanations

## 4.1 Condensing dryer alarm code

Error code	Error description	Error type	Check content
“  ” is flashing	Container is full; Water pump failure or water level sensor failure	Pause the program; Can restore	Check the water storage container; Check the pump; Check the water level sensor
“  ” is flashing	Filter is plug up or environment temperature is too high	Pause the program; Can restore	Clean filter and confirm the ambient temperature
E32	The humidity signal error	Program after newspaper;Can restore	Check the humidity signal
E33	The air inlet sensor error	Termination of the program;Can not be restored	Check the air inlet sensor connector

# 5 TROUBLESHOOTING

## Circuit diagram of dryer

### The circuit program

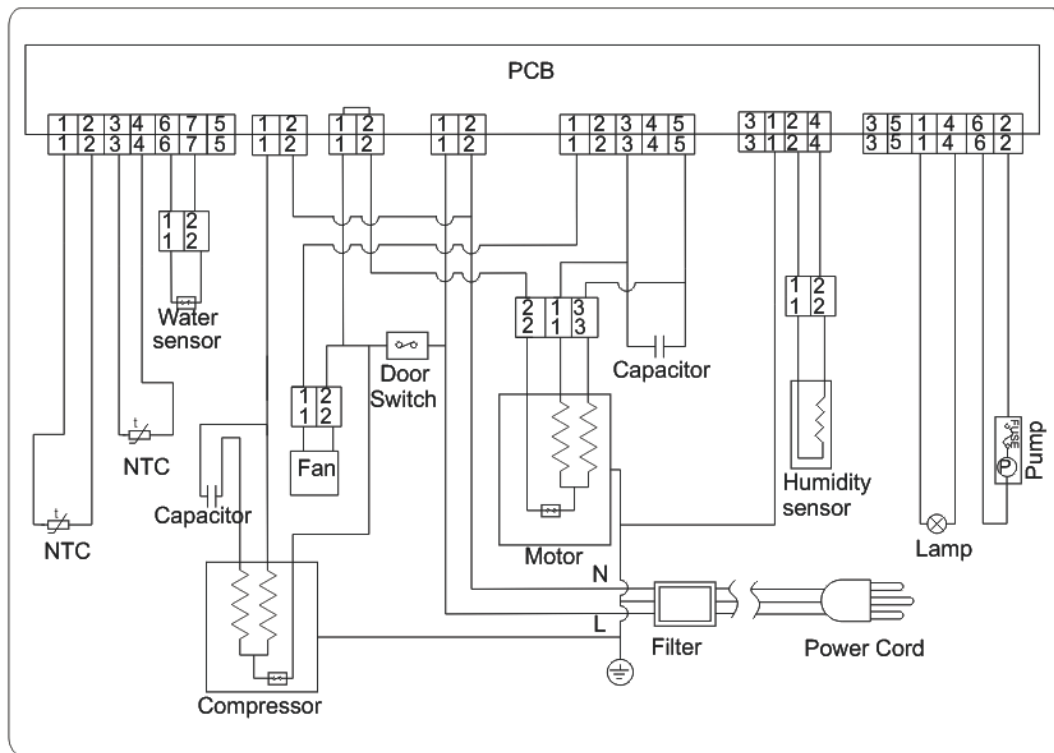

### Wiring connection figure

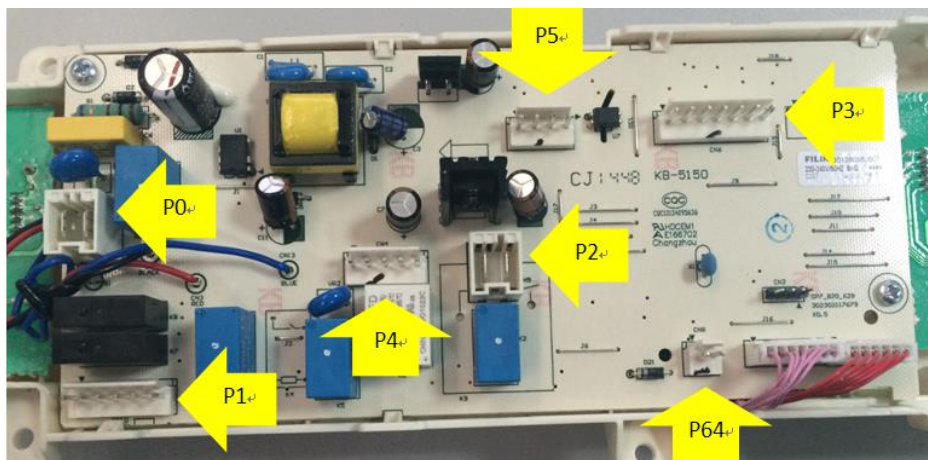

P0	Live wire + neutral wire
P1	LAMP and PUMP
P2	Compressor
P3	water sensor +front NTC+rear NTC
P4	motor and fan
P5	humidity sensor+ground wire
P6	door

# 5 Troubleshooting

## 5.1 The dryer breaks down and the control panel can not display

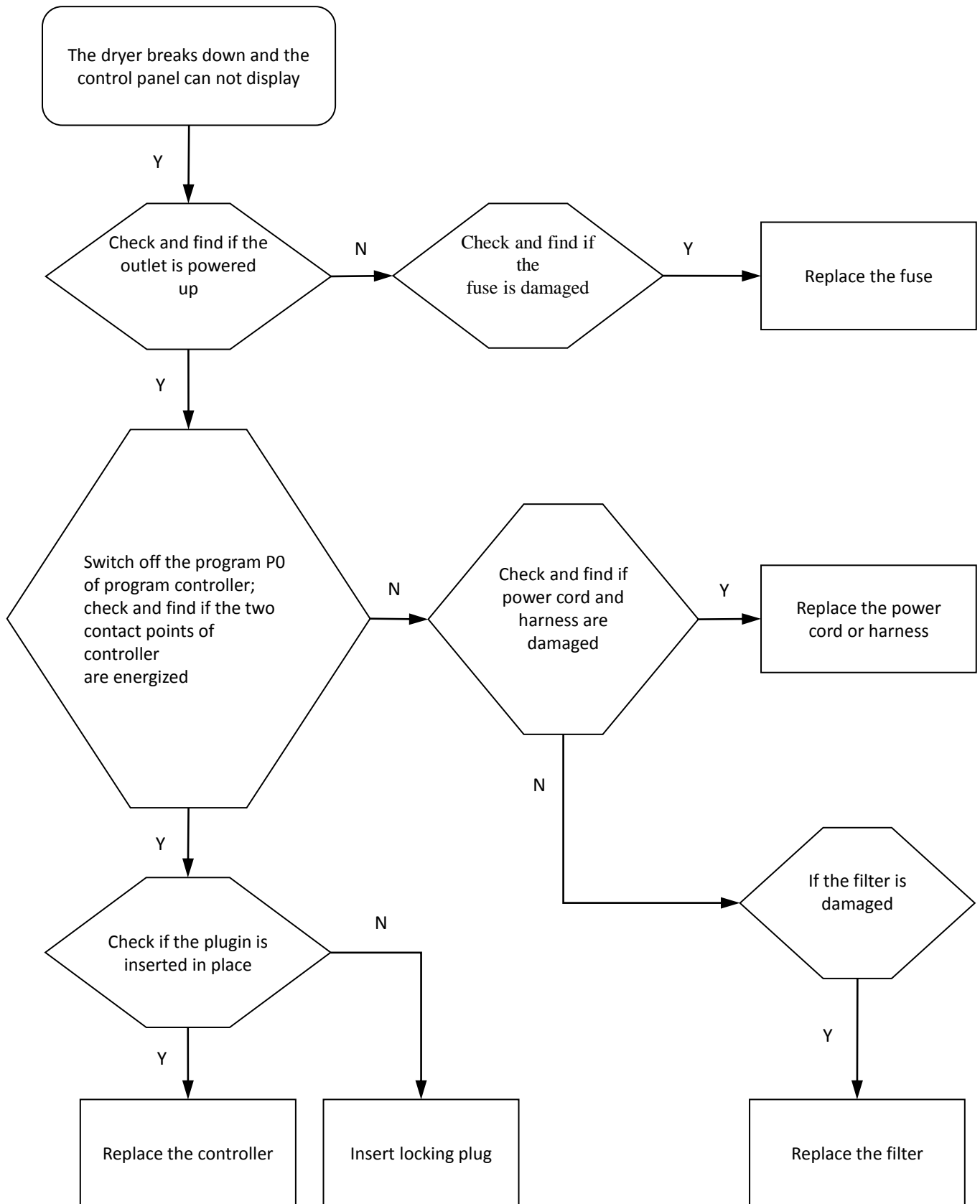

# 5 Troubleshooting

## 5.2 The drum does not spin but the control panel can display

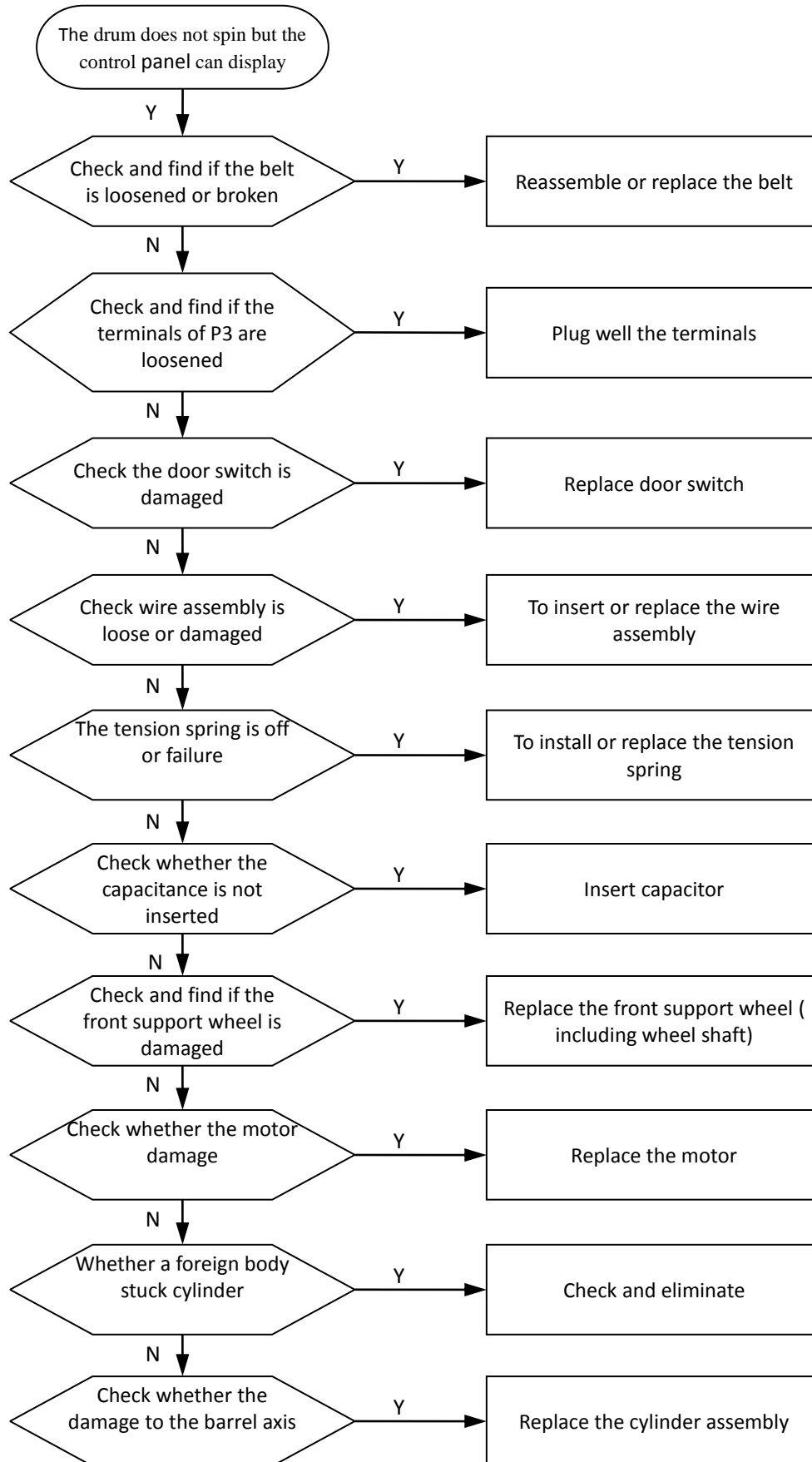

# 5 Troubleshooting

## 5.3 The heating system does not work

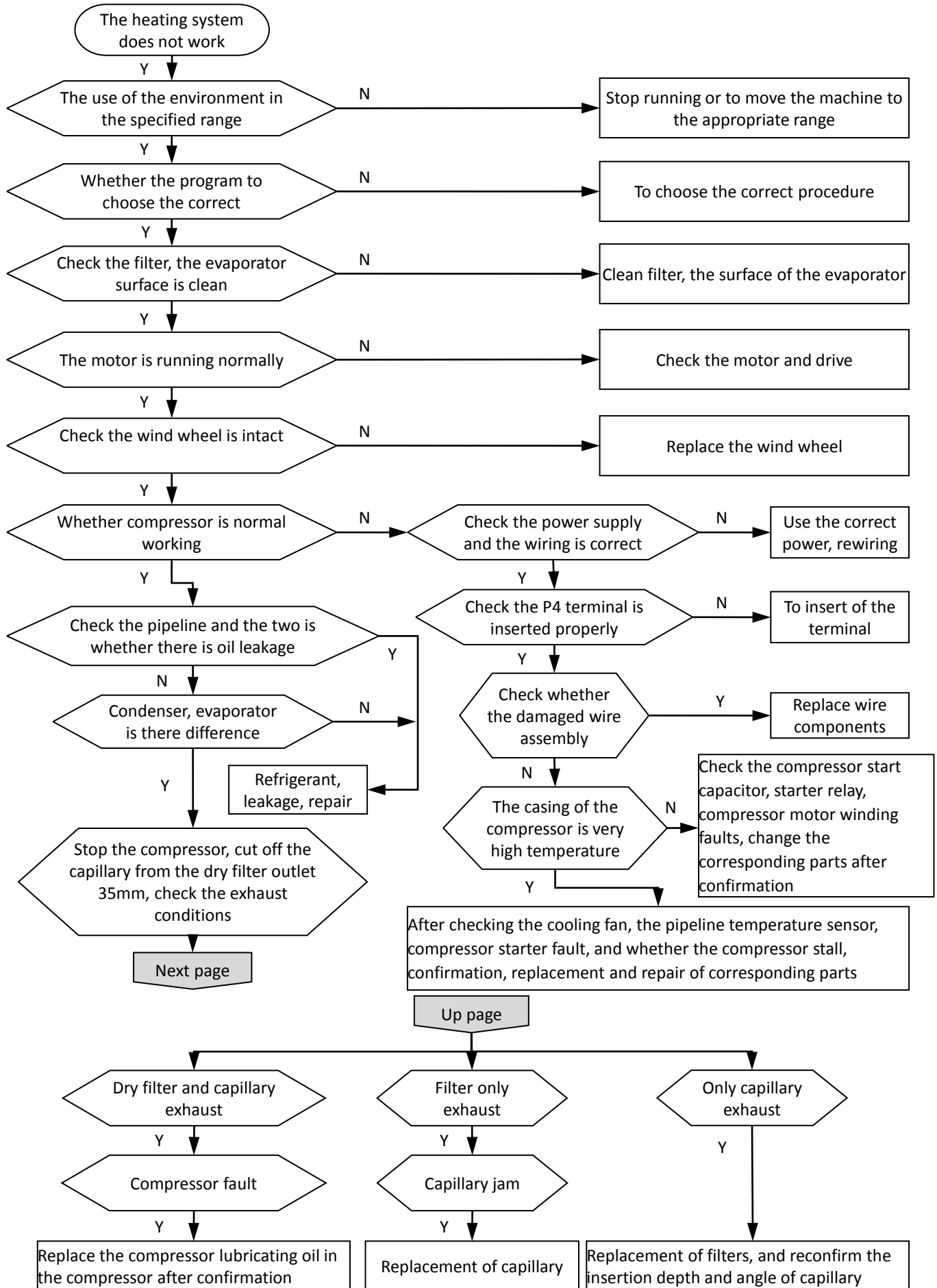

# 5 Troubleshooting

## 5.4 The dryer makes abnormal noise when operating

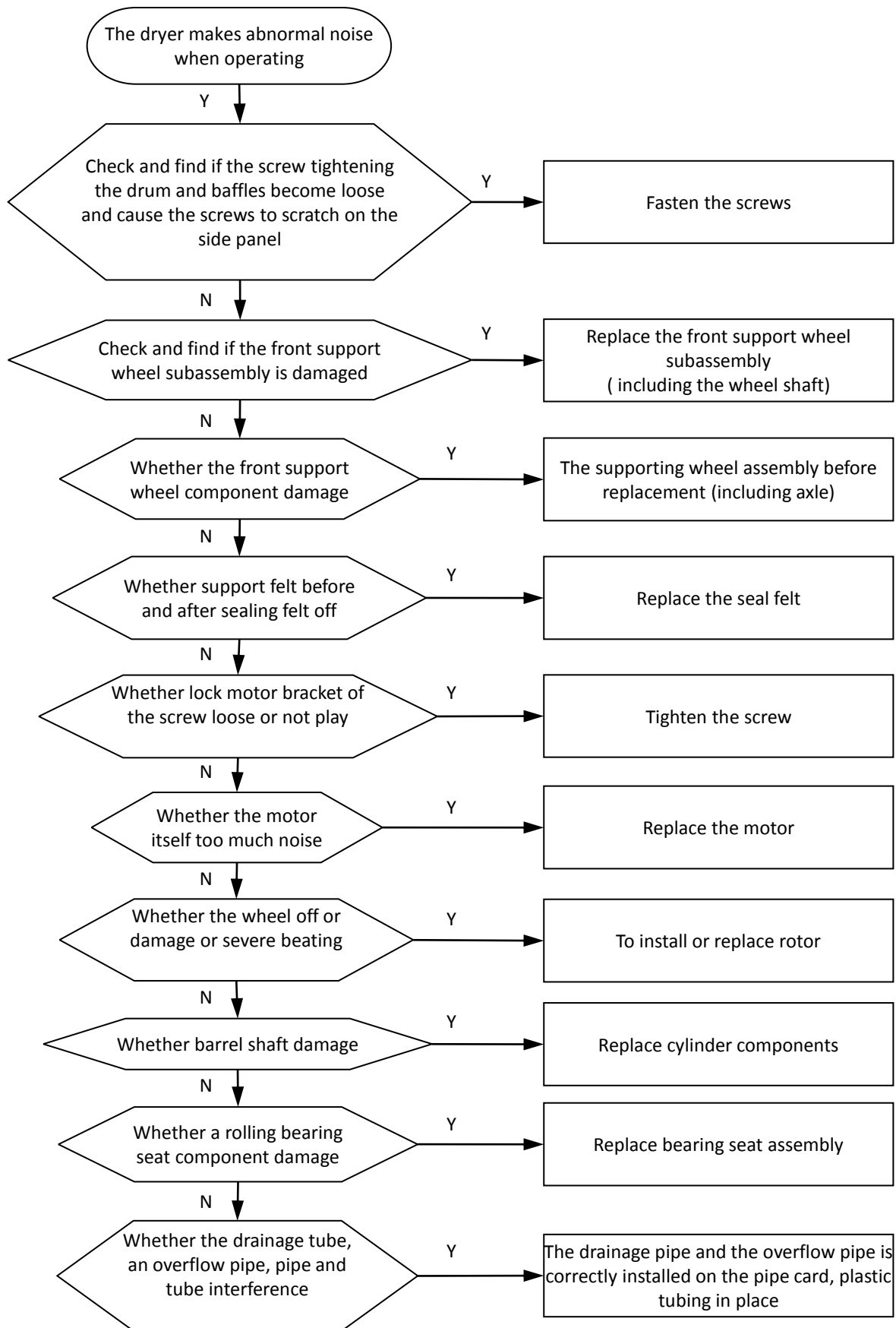

# 5 Troubleshooting

## 5.5 The dryer gives out abnormal smell when operating

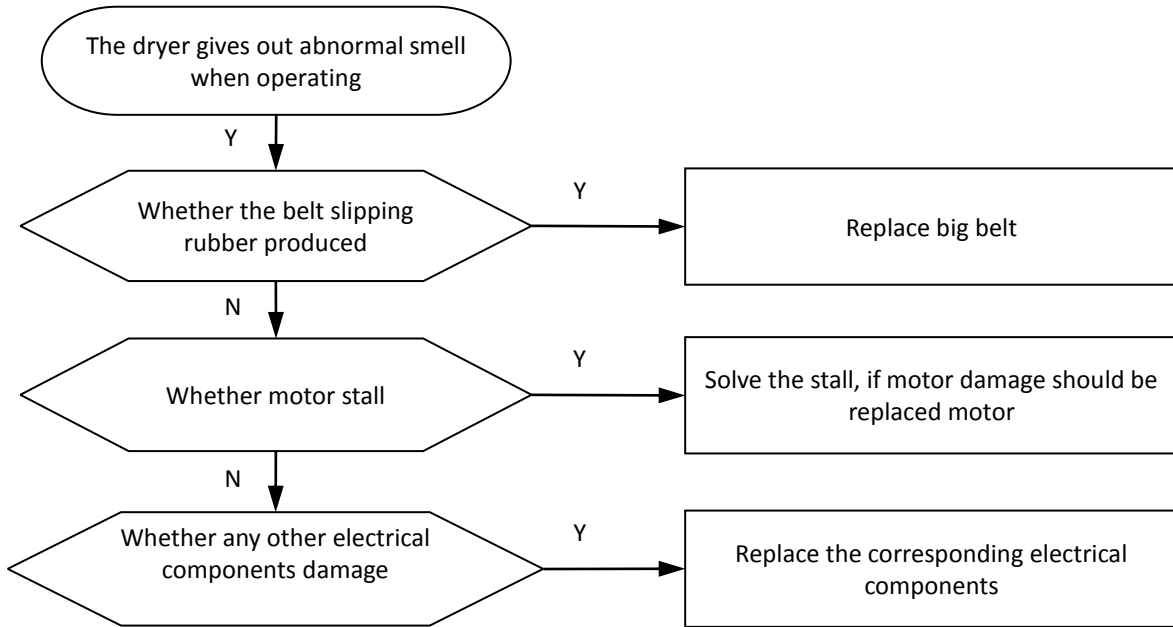

## 5.6 Dryer work LED screen shows TANK

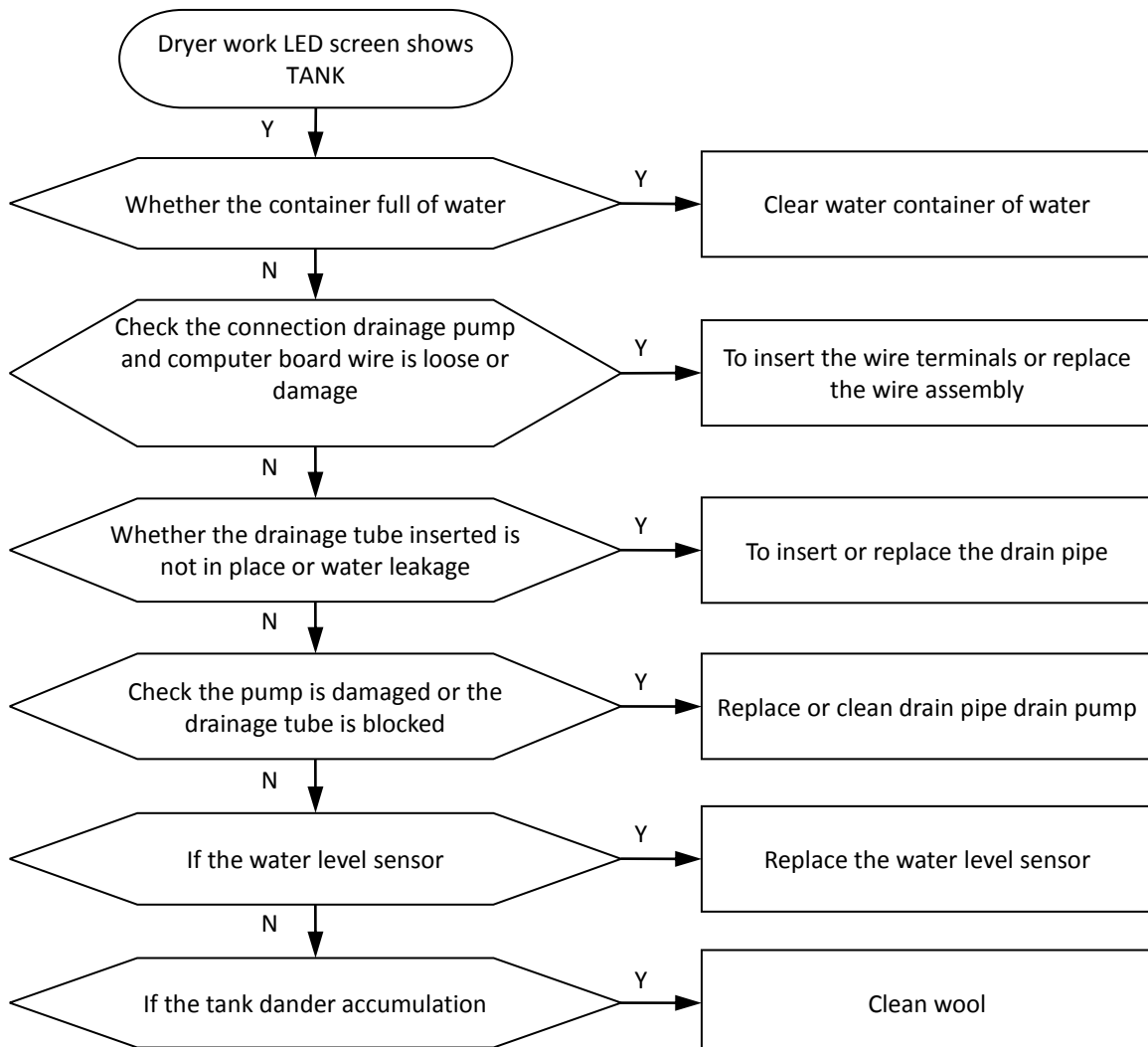











# 5 Troubleshooting

## 5.7 Heat pump system parts repair:

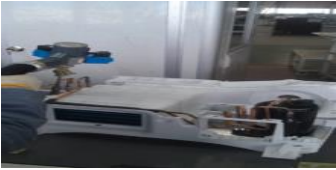
Warning : If the heat pump system parts need repair , we suggest you buy new machines rather than repair. The heat pump system parts include capillary , dry filter, connect pipe, condenser, evaporator, compressor and etc.

### 5.7.1 Capillary and dry filter repair

Operation step	Picture
Release refrigerant	
Melt capillary and dry filter	
Prepare new part	
Weld capillary ,dry filter and connect pipe	
Vacuumize	
Fill refrigerant ( R134a &310g )	
Seal	
Leak hunting	
Face lifting	









# 5 Troubleshooting

## 5.7.2 Condenser and evaporator repair

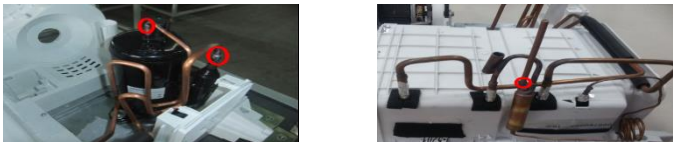
Operation step	Picture
Release refrigerant	
Melt condenser and evaporator	
Prepare new part	
Weld condenser , evaporator, capillary, dry filter and connect pipe	
Vacuumize	
Fill refrigerant ( R134a &310g )	
Seal	
Leak hunting	
Face lifting	

# 5 Troubleshooting

## 5.7.3 Compressor repair

Operation step	Picture
Release refrigerant	
Melt compressor and connect pipe	
Prepare new part	
Weld compressor and connect pipe	
Vacuumize	
Fill refrigerant ( R134a &310g )	
Seal	
Leak hunting	
Face lifting	

# 6 Check Point Of Circuit

Before repairing, use multimeter to judge circuit stand of fail.

No	Part	Test Description	parameters
1	Electric Filter	With a multimeter to test the connection at both ends of the N and L are each turned on. Conducting OK, the replacement is not turned on	250VAC 50/60HZ 16A@40°C
2	Seal Thermistor	Measured across the resistor with a multimeter, the resistance line with RT table. According to the prevailing ambient temperature determination, error $\pm 3$ °C.	5°C:12KΩ 10°C:9.5KΩ 15°C:7.5KΩ 20°C:6KΩ 25°C:4.8KΩ 30°C:3.9KΩ 35°C:3.1KΩ
3	Capacitor	Test capacitance value should be $7.5 \pm 5\%$ uF	7.5μF±5% 450VAC 50/60HZ
4	Capacitor	Test capacitance value should be $16 \pm 5\%$ uF	16μF/450V
5	Lamp	And holders together through the rated voltage, see if you can light up	220-240V 15W
6	Holder Lamp	And barrel lamps together through the rated voltage, see if you can light up	LED-4
7	Drain Pump	Both ends of the drain pump through the nominal voltage to see if the drainage	220-240V, 50HZ, 0.8m, 4L/min, 13W
8	Water Level Sensor	Conducting both ends with a multimeter test case, disconnect the float at the bottom of the float at the top of turn	10mv-24vAC;10mv-200vDC ,10VA 10W, 10UA-1A(DC)
9	Cover Switch	Conducting both ends with a multimeter test case, under normal disconnect, press on.	Minimum load DC 5V 1mA, rated load AC125V 1A / AC250V 0.5A, minimum load DC 5V 1mA, RoHS
10	Motor Assembly	Measured with a multimeter primary and secondary windings of the motor. Main winding - $26.0 \times (1 \pm 10\%)$ (Green Orange) Ω (20 °C) Secondary winding (red - orange) $26.0 \times (1 \pm 10\%)$ Ω (20 °C)	220- 240V/50HZ,120W,Al,RoHS
11	Internal Wire Assembly	Watch the terminals and wires for damage	UL,RoHS
12	Power Cord	Watch the terminals and wires are damaged, the plug and the corresponding line multimeter to measure whether conduction.	1.5m,Gray, 250V/16A, H05VVf3*1.0,VDE,ROHS

# 7 Service tools

---



Number	Tools	Suitable kit
1	Sleeve (14#) or spanner	drum tub assembly
2	Sleeve (10#) and pliers	Wheel Assembly
3	Other tools (screwdriver, pliers and so on)	Common service tools

# 8 Appendix

---

Machine function description, program description, the whole detailed parameter table, fault codes, etc. Please refer to the instructions.

Note: The schedule for the reference value.



说明书

**The end!**