

Tumble Heat Pump Dryer

Model:

MDK100-CH01B/B05E-EU(A3)-C5

MDK90-CH01B_B05E-EU_A3-C5

MDK80-CH01B_B05E-EU_A3-C5

MDK90-CH01B_B05E-AU_6-C5

MDK80-CH01B_B05E-AU_6-C5

Service Manual



Note:

**Before maintaining this product, please read the manual first.
Contact your service center if there's any problem.**

Contents

1. Precaution.....	3
1.1 Precaution	
1.2 Servicing Precautions	
1.3 Cautions for Safety	
2. Factory Pattern Detection	9
3. Disassembling Ways of Main Parts	10
4. Malfunctions Codes and Explanations	20
5. Troubleshooting	21
5.1 The dryer breaks down and the control panel can not display	
5.2 The drum does not spin while the control panel can display	
5.3 The heating system does not work	
5.4 The dryer makes abnormal noise when operating	
5.5 The dryer gives out abnormal smell when operating	
5.6 Dryer’s ‘Full’ LED is lighting	
5.7 E32 LED is lighting after the cycle finished	
5.8 E33 LED is lighting	
5.9 E50 LED is lighting after the cycle finished(only for BLDC model)	
5.10 E60 LED is lighting after the cycle finished(only for BLDC model)	
5.11 E82 LED is lighting	
5.12Heat pump system parts repair	
6. Check Point of Electronic Components	31
7. Service Tools	32
8. Appendix.....	33

When executing troubleshooting or replacing components, please note the following safety precautions:

1.1 Safety Precautions

1-1-1. Use Genuine Parts

The components of the machine have safety features such as non-combustibility and voltage withstanding. Therefore, always use the same part as suggested by the manufacturer. Ensure sure to use the components from designated manufacturer especially the key safety components.

1-1-2. Grounding

Connect the grounding wire to the shell plate, and bury it at least 25cm underground : alternatively, connect the ground wire to the appropriate pin on a properly grounded power receptacle. Never connect the wire to a telephone line, lightning rod, or gas pipe.

1.2 Servicing Precautions

1-2-1. Observe Warnings

Be sure to follow special warning and precautions that are described on part labels and in the owner's manual.

1-2-2. Parts Assembly and Wiring

Be sure to use insulation material (such as tube and tape). And be sure to restore all parts and wires to their original positions. Take special care to avoid contacting with sharp edges.

1-2-3. Perform Safety Checks after Servicing

After servicing, check that the screws, parts, and wiring are restored to their original positions, and check the insulation between the external metals and the socket plug. In addition, place the tumble dryer in a level position (less than 1(one) degree) to prevent vibration and noise during operations.

1-2-4. Insulation Checks



Pull out the plug from the power receptacle, put wet clothes into the drum, and then set the timer. Check that the resistance insulation between the terminals of the plug and the externally exposed metal is greater than $1M\Omega$.



Note :When it is impossible to perform insulation check with a 500V insulation resistance tester, use other testers for inspection.

1 Precaution

1.3 Cautions for Safety

- Please observe the following notes for safety.
- The symbols indicate as follows.

Symbol	Meaning
 WARNING	<ul style="list-style-type: none">• Indicates possibility of death or serious injuries to repair technicians or people nearby for improper operations, or to the users by the defective products after technician operations.
 CAUTION	<ul style="list-style-type: none">• Indicates possibility of injuries or physical damages to repair technicians or people nearby for improper operations, or to the users by the defective products after technician operations.

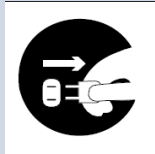
Graphic Symbol	Meaning
 ELECTRIC SHOCK	<ul style="list-style-type: none">• Indicates a caution (including a warning). Specific instruction is followed by a graphic or characters in or near. Symbol left warns an electric shock.
 DO NOT DISASSEMBLE	<ul style="list-style-type: none">• Indicates prohibition (act must not be conducted). Specific instruction is followed by a graphic or characters in or near. Symbol left warns not to disassemble.
 UNPLUG POWER	<ul style="list-style-type: none">• Indicates forcing (act must be conducted). Specific instruction is followed by a graphic or characters in or near. Symbol left warns to unplug the power cord.

1 Precaution

1.3 Cautions for Safety

- Please observe the following notes for safety.
- The symbols indicate as follows.



WARNING



OUT OF CHILD

- Advise the customer to keep children out of the work place. Children may be injured by a tool or disassembled part.



UNPLUG POWER

- Unplug power cord for the work such as disassembling which is unnecessary to be power on. Do not hold the plug by a wet hand. Failing to unplug may cause an electric shock.



USE REPAIR PARTS

- Use the specified repair parts when repairing the product. Otherwise, a malfunction or defect may occur. Also, a short circuit, ignition or other danger to the customer may occur.



CHECK INSULATION RESISTANCE

- After repair, measure insulation resistance between the charging part (power cord plug) and the non-charging metallic part (ground) with an insulation resistance meter (500V). The resistance shall be 10MΩ or more. Failing to check the insulation resistance may cause a short circuit, electric shock or other diseases to the customer.

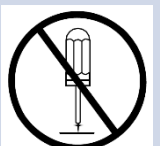

DO NOT MODIFY

- Do not modify the product. An electric shock or ignition may occur.



DO NOT DISASSEMBLE AND REPAIR

- Only a repair technician can disassemble and repair. An electric shock, ignition or malfunction may cause injury.

1.3 Cautions for Safety



WARNING



USE EXCLUSIVE SOCKET

- Use an exclusive socket for the machine. Otherwise, an electric shock or ignition may occur. Sharing the same socket with other instrument causes heating of a branch socket and may result in a fire.

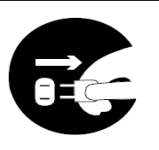

CONNECT GROUNDING WIRE

- Unplug power cord for the work such as disassembling which is unnecessary to be power on. Do not hold the plug by a wet hand. Failing to unplug may cause an electric shock.



CONNECT GROUNDING WIRE

- Connect the grounding wire. Failing to do so may cause an electric shock when a short circuit occurs. Consult an electric work shop or a sales shop.



DO NOT USE WET PLACE

- Do not install in a bath room or a place exposed to wind or rain. An electric shock or a short circuit may cause a fire.

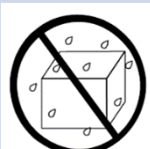

DO NOT SPLASH WATER

- Do not pour or immerse electrical parts into water or liquid solution. An electric shock or ignition may occur.



REMOVE DUST

- Wipe off dust adhering to the plug of power cord. Dust may cause a fire.

1.3 Cautions for Safety



WARNING



**AVOID
INFLAMMABLE**

- Do not put inflammable into the tumble dryer.
Do not put cloths stained with kerosene, gasoline, benzene, thinner, alcohol, etc.
It may cause a fire or explosion.



**DO NOT TOUCH
THE DRUM**

- Do not touch the drum before the drum is cool down.



CAUTION



**INSTALL
CAREFULLY**

- Ask an electric work shop to install the product.
Install the product securely and safely according to the electrical equipment technical standard and the wiring standard.
Incorrect work causes an electric shock or fires.



DO NOT PULL

- Do not pull the power cord when unplugging.
Hold the power plug to unplug.
An electric shock or short circuit may cause a fire.

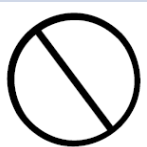

DANGER HAND

- Do not put your hand under the tumble dryer during operation.
There is a rotary part under the machine which may cause an injury.

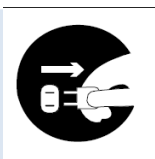

When the repairing work is done, select the “Time” programme to operate the dryer for at least 10 minutes. During this time, check the dryer if the drum is turning right and there is no undesired noise. After the programme is done, open the door, and check the drum with your hand. If the drum is warm, it means the dryer operates well.

WARNING



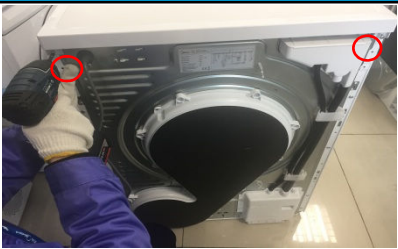
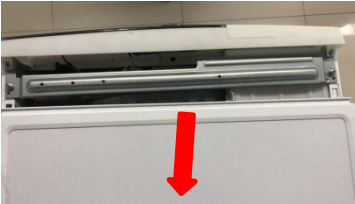

UNPLUG POWER

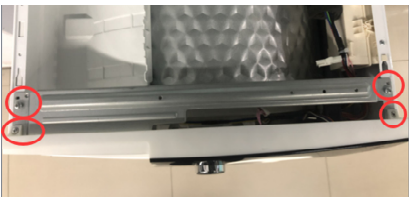

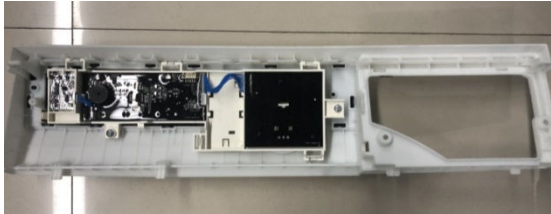
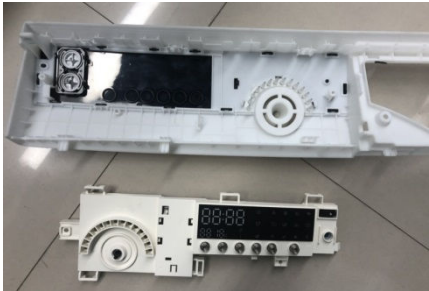

- Unplug power cord for the work such as disassembling which is unnecessary to be power on. Do not hold the plug by a wet hand. Failing to unplug may cause an electric shock.

ITEM	PICTURE
<p>Unscrew 2 screws at the back of the top cover assembly.</p>	
<p>Remove the top cover assembly.</p>	
<p>Pull out the drawer.</p>	
<p>Unscrew 2 screws in the front of control panel with cross screwdriver.</p>	
<p>Unscrew 4 screws on the top with cross screwdriver.</p>	



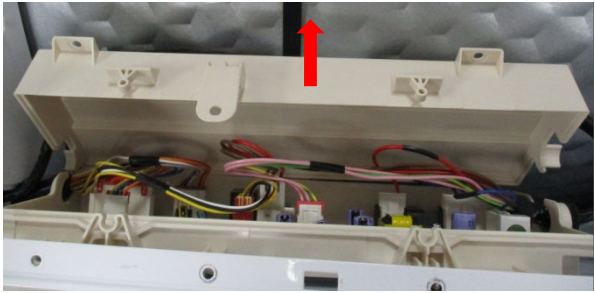

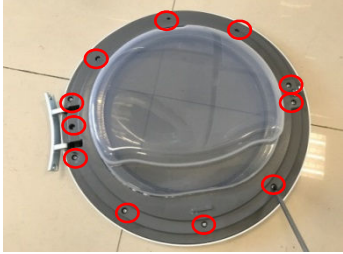

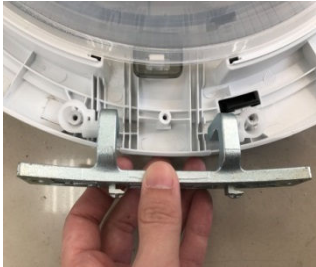
3 Disassembling Ways of Main Parts

ITEM	PICTURE
<p>Pull out the cycle select knob.</p>	
<p>Remove 5 screws between the control panel and the PCB housing. Remove control panel.</p>	
	
	
<p>Remove 2 screws.</p>	



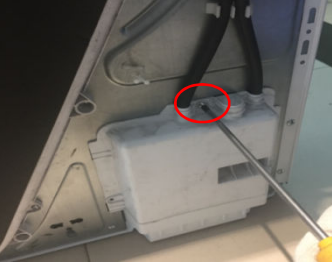

3 Disassembling Ways of Main Parts

ITEM	PICTURE
Open the protection cover and take off.	
Pull out all connection pins and take off the control panel.	
Unscrew 2 screws on the door hinge.	
Unscrew 11 screws on the inner ring.	
Remove the inner ring.	
Take off the door hinge.	

3 Disassembling Ways of Main Parts

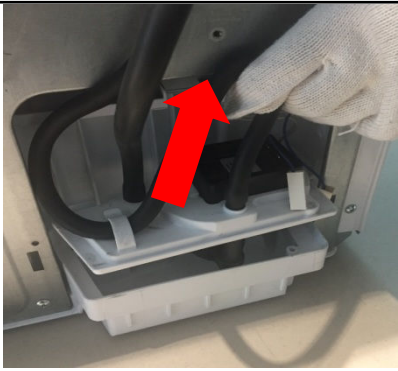

ITEM	PICTURE
Take off the door plunger.	
Pull out the drain pipe.	
Unscrew 1 screw on the rear cover of drain pump kit.	
Remove the rear cover of drain pump kit.	
Pull out the connection pins on the drain pump.	
Pull out the wire terminal of water level sensor.	

3 Disassembling Ways of Main Parts

ITEM	PICTURE
Unscrew 1 screw on the pump cover.	
Take off the pump cover.	
Pull out the drain hose and overflow tube.	
Take off the water level sensor.	
Take off the drain pump	

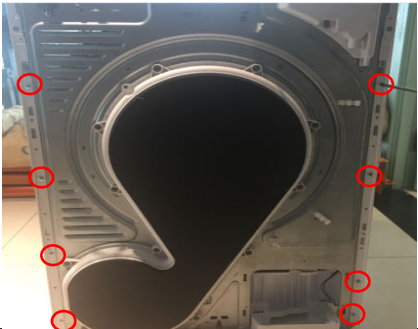

3 Disassembling Ways of Main Parts

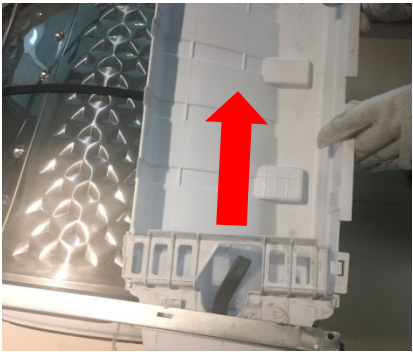

ITEM	PICTURE
Unscrew 2 screws on the top of the front panel.	
Unscrew 8 screws at the back of side plates.	
Remove the side plates(left and right).	
Unscrew 1 screw at the back of housing drawer.	
Pull out the housing drawer.	

3 Disassembling Ways of Main Parts

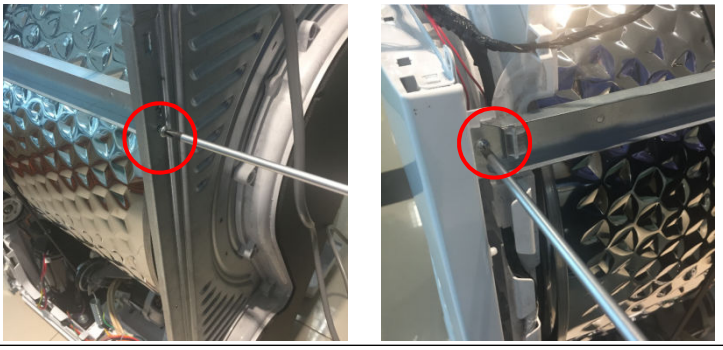
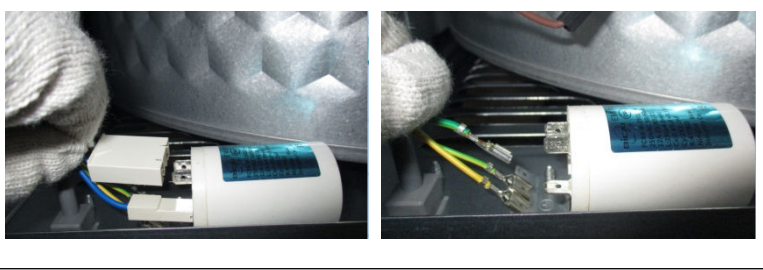

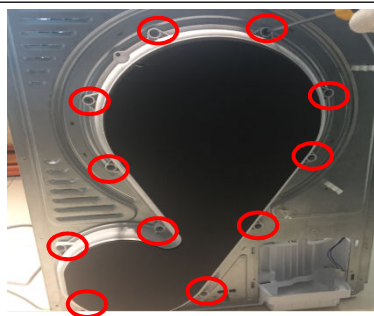

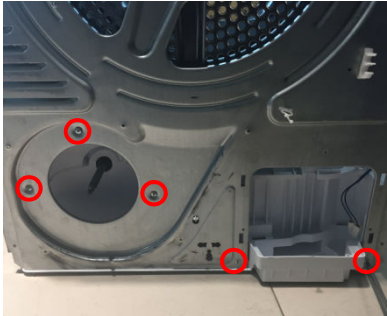
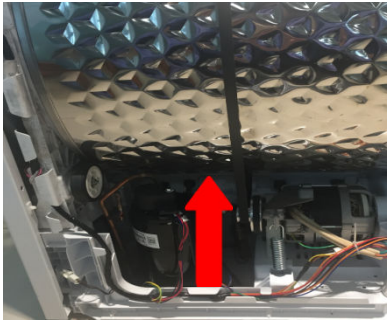
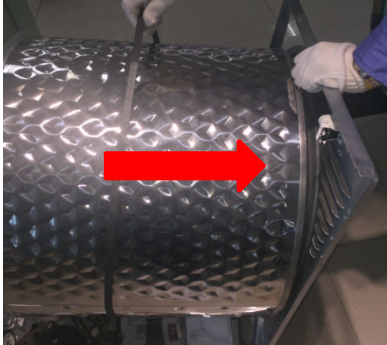
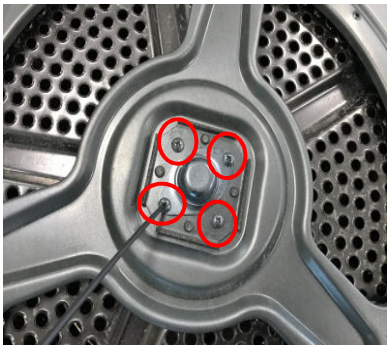

ITEM	PICTURE
Unscrew 4 screws on the side brackets (left and right).	
Pull out the wire terminals of electric filter and ground line.	
Unscrew 1 screw of the power line.	
Remove the power line.	
Remove all of the screws on the back cover and take it off.	

3 Disassembling Ways of Main Parts

ITEM	PICTURE
Unscrew the nut(M10) and remove the impeller.	
Unscrew 5 screws on the cabinet cover back.	
Lift up pulley of the motor and remove the belt.	
Separate the tub assembly.	
Unscrew 4 screws on the bearing house assembly and remove the bearing cover.	

3 Disassembling Ways of Main Parts

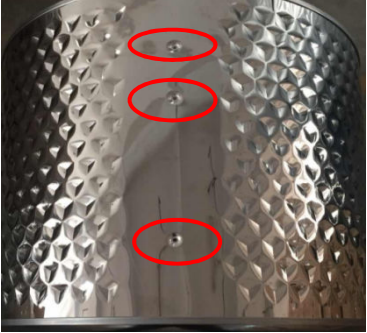





ITEM	PICTURE
Unscrew the nut(M14) and remove the bearing house assembly.	
Separate the cabinet cover back from the tub.	
Take off the felt ring seal on the cabinet cover back.	
Unscrew the screw barrel.	
Remove the lifter.	

3 Disassembling Ways of Main Parts

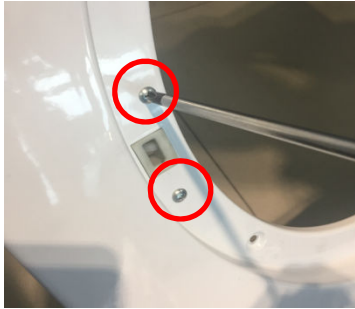

ITEM	PICTURE
<p>Unscrew 4 screws of the taper cap.</p>	
<p>Remove the taper cap.</p>	
<p>Remove the maintenance cover, and take out the filter. Remove the cooling fan cover.</p>	
<p>Remove the filter lint assembly and door seal.</p>	
<p>Remove 9 screws on the front door.</p>	

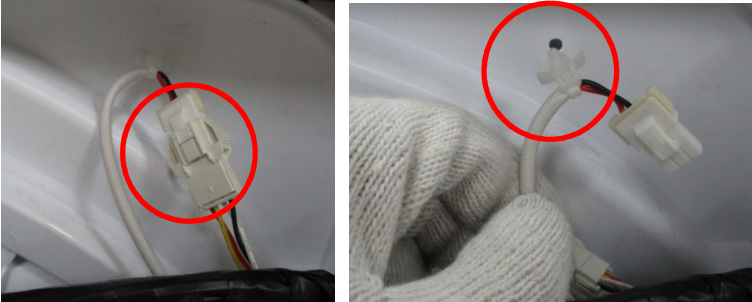
3 Disassembling Ways of Main Parts

ITEM	PICTURE
<p>Unscrew 2 screws of the door lock and remove the front panel.</p>	
<p>Pull out the wire terminals from door lock.</p>	
<p>Pull out the wire terminal of light. Pull out the button from the front support assembly .</p>	
<p>Pull out the wire terminal from NTC.</p>	
<p>Pull out the wire terminals of humidity sensor and cooling fan.</p>	

3 Disassembling Ways of Main Parts



ITEM	PICTURE
<p>Remove 5 screws of the front support.</p>	
<p>Remove the wire components. Take off the front support.</p>	
<p>Unscrew 2 screws of the lamp and remove the lamp cover.</p>	
<p>Remove the lamp.</p>	
<p>Remove 3 screws on the humidity sensor support.</p>	

3 Disassembling Ways of Main Parts

ITEM	PICTURE
<p>Pull out the wire terminals of the humidity sensor support and remove the wires.</p>	
<p>Take off the felt ring seal on the front support.</p>	
<p>Unscrew the nuts and remove the wheels.</p>	
<p>Remove the screw on the safe cover and take it off. Pull out the terminals of capacitances.</p>	
<p>Remove 1 screw and take off the capacitances.</p>	

3 Disassembling Ways of Main Parts

ITEM	PICTURE
<p>Remove the tension spring.</p>	
<p>Remove all the wire terminals of the motor and the choke.</p>	
<p>Remove 2 screws and take off the motor.</p>	
<p>Remove 2 screws and take off the choke.</p>	
<p>Unscrew the grounding screw and remove all wires on the top of the compressor.</p>	



3 Disassembling Ways of Main Parts



ITEM	PICTURE
Remove the two NTC.	
Take off the internal wire assembly from base assembly.	
Remove all screws from the cover of heat exchangers and take it off.	
Unscrew the nuts of compressor and remove the heat exchangers(2 persons to lift the unit)	
Unscrew 3 screws and remove the blower collet of compressor.	

3 Disassembling Ways of Main Parts

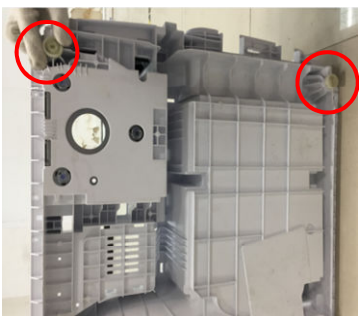

ITEM	PICTURE
Remove 1 screw and take off the fan.	
Pull out NTC.	
Remove the condenser clap plate.	
Remove two foot screws.	

4 Malfunctions Codes and Explanations



Lamp Display Error code(flashes)	Error description	Error type	Check content
Full (Light on permanently)	Container is full; Drain pump failure\ water level sensor failure or drain hose failure	The program pause; Can restore after restart the machine;	Check the water storage container; Check the drain pump ; Check the water level sensor (consult 5.6)
E32	The fault of humidity sensor; Two parts of the sensor metal joint together	Warn when the cycle completed; Restorable	Check the humidity sensor and change control panel (consult 5.7)
E33	The fault of NTC	Termination of the program ; Not restorable	Check the NTC connecting wire (consult 5.8)
E50	The motor does not turn	The motor failure.	Check the power supply and change the motor (consult 5.9)
E64	The motor communication error	Terminals of motor or control panel failure.	Check the terminal and change the motor (consult 5.10)
E82	The PCB communication error	The connection of control panel and displayed panel failure.	Check the connecting wire(consult 5.11)

Circuit diagram of dryer

The circuit program

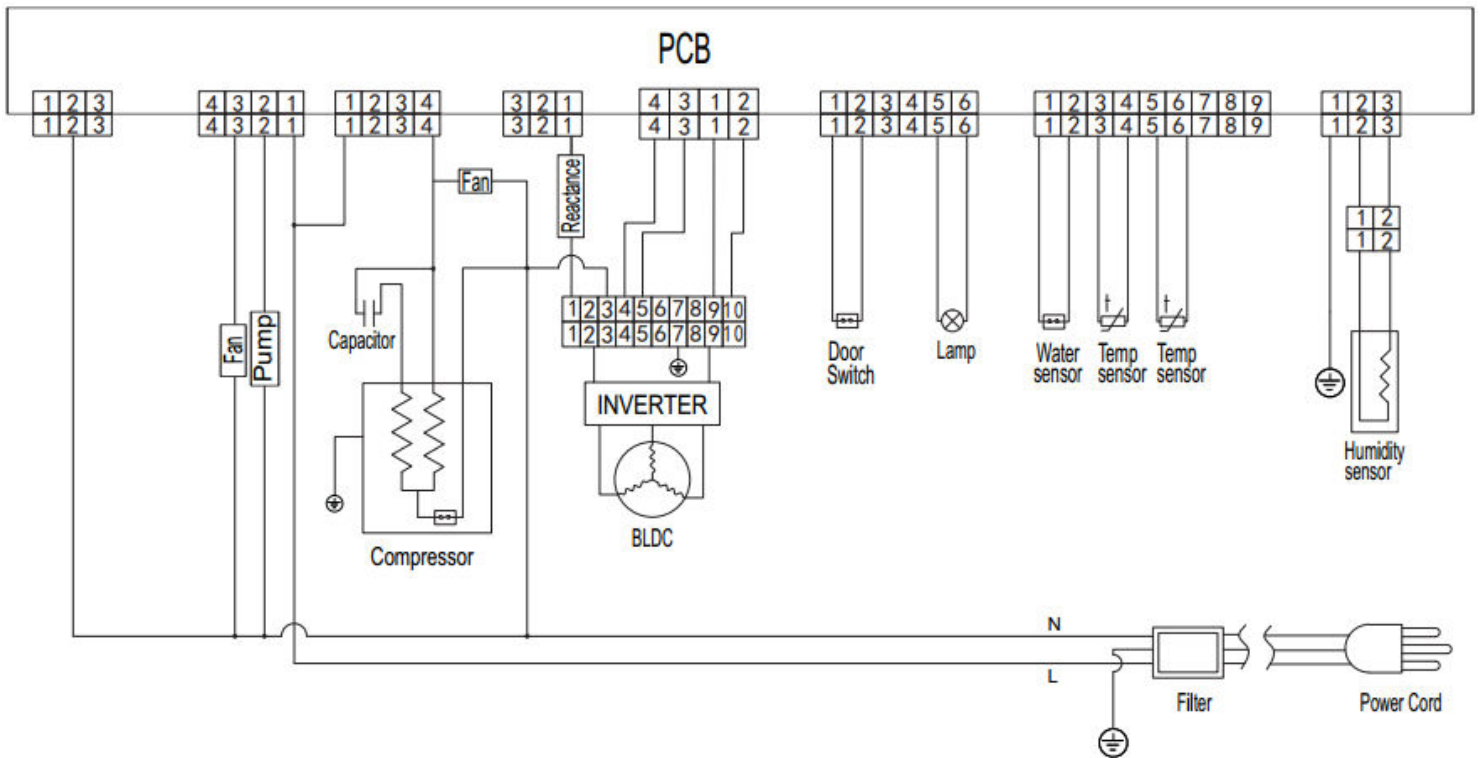

Circuit diagram of dryer

Wiring connection figure

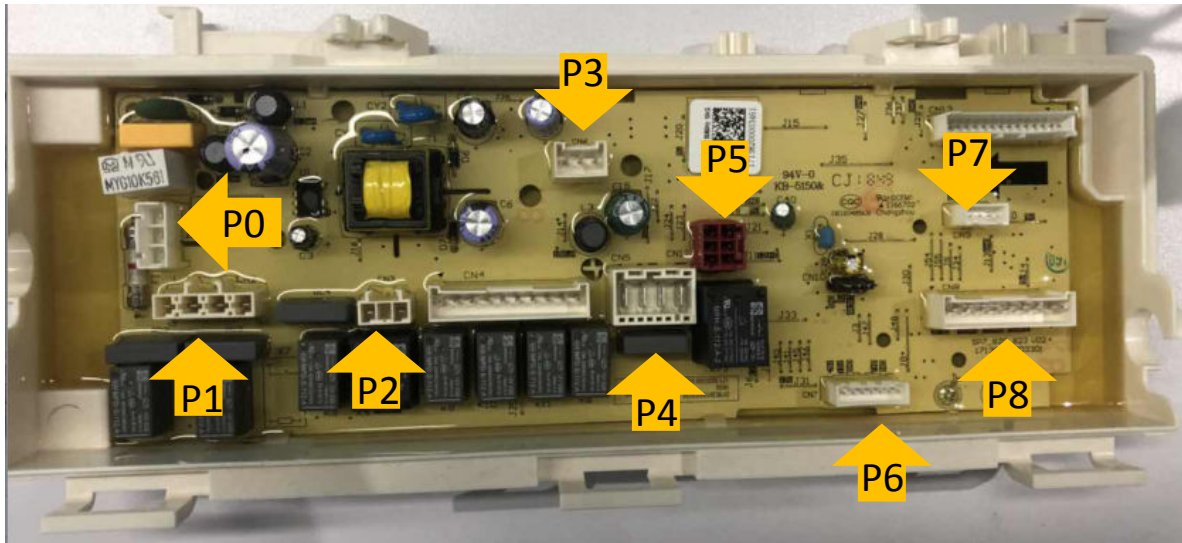

P0	Neutral wire
P1	Live wire + Drain pump + Cooling fan
P2	Motor
P3	Humidity sensor
P4	Compressor
P5	Door switch + Lamp
P6	Communication between Displayed panel and Control panel
P7	Motor communication
P8	Water level sensor +NTC1+NTC2

5.1 The dryer breaks down and the control panel can not display

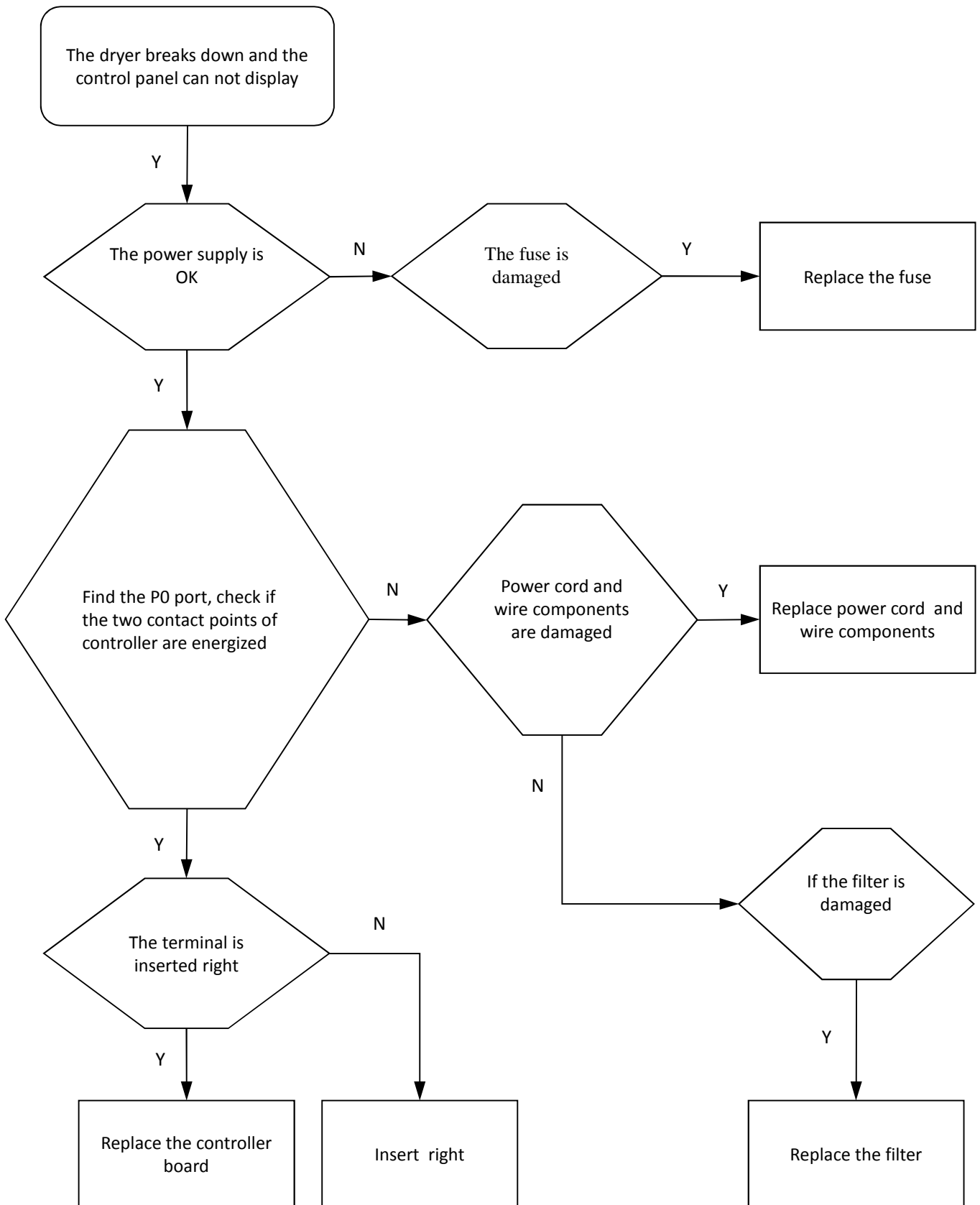

5.2 The drum does not spin while the control panel can display

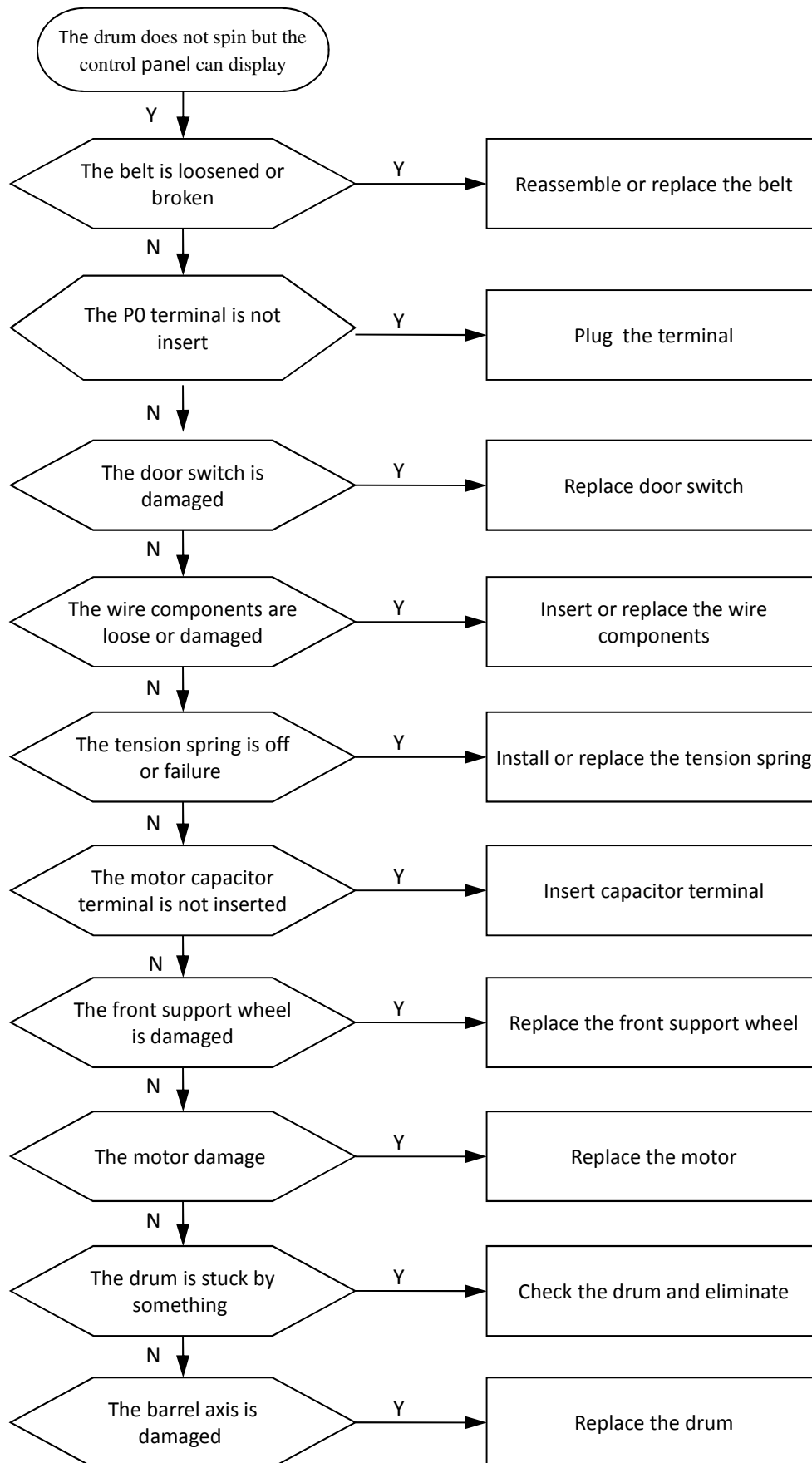

5.3 The heating system does not work

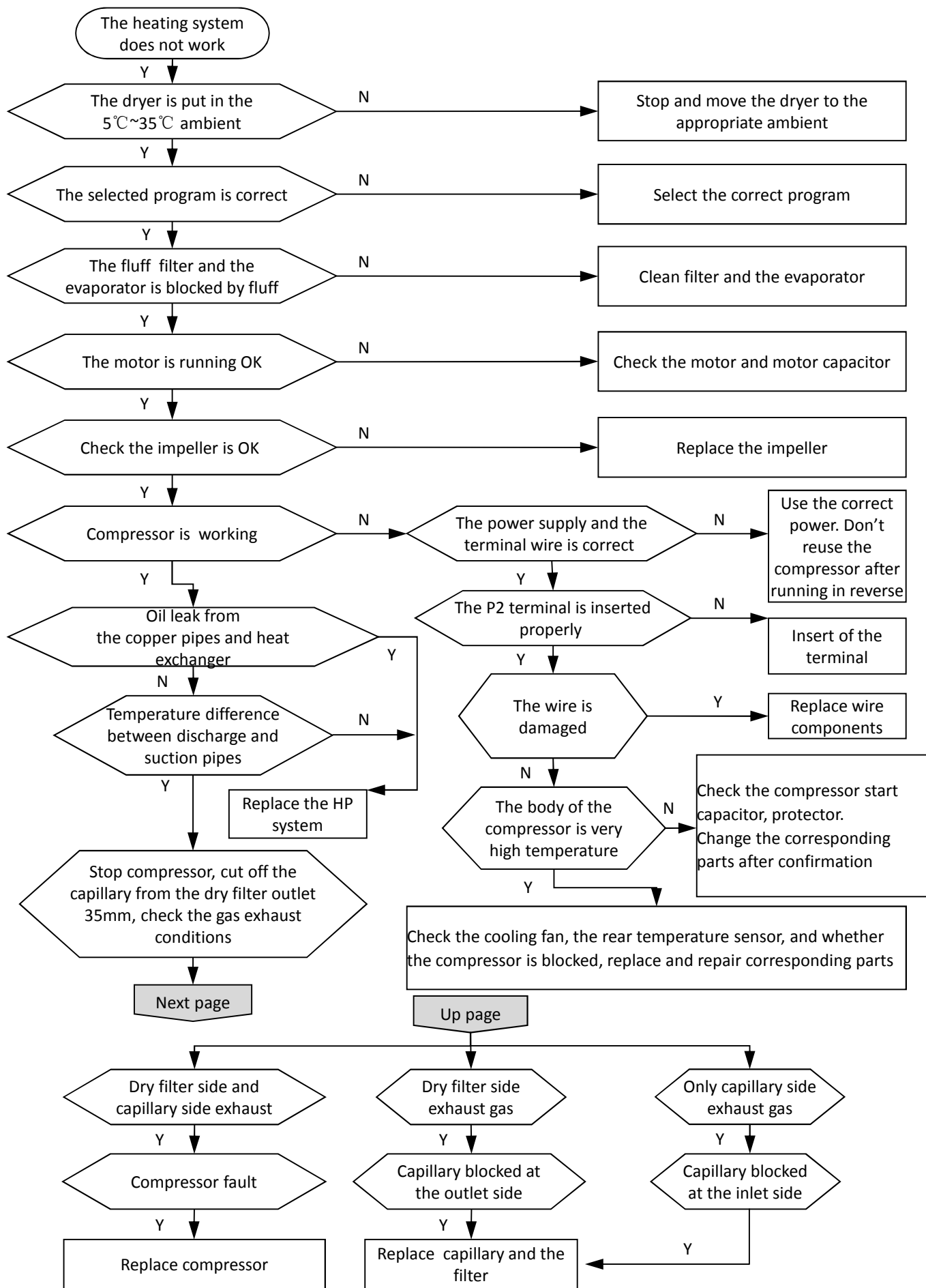

5.4 The dryer makes abnormal noise when operating

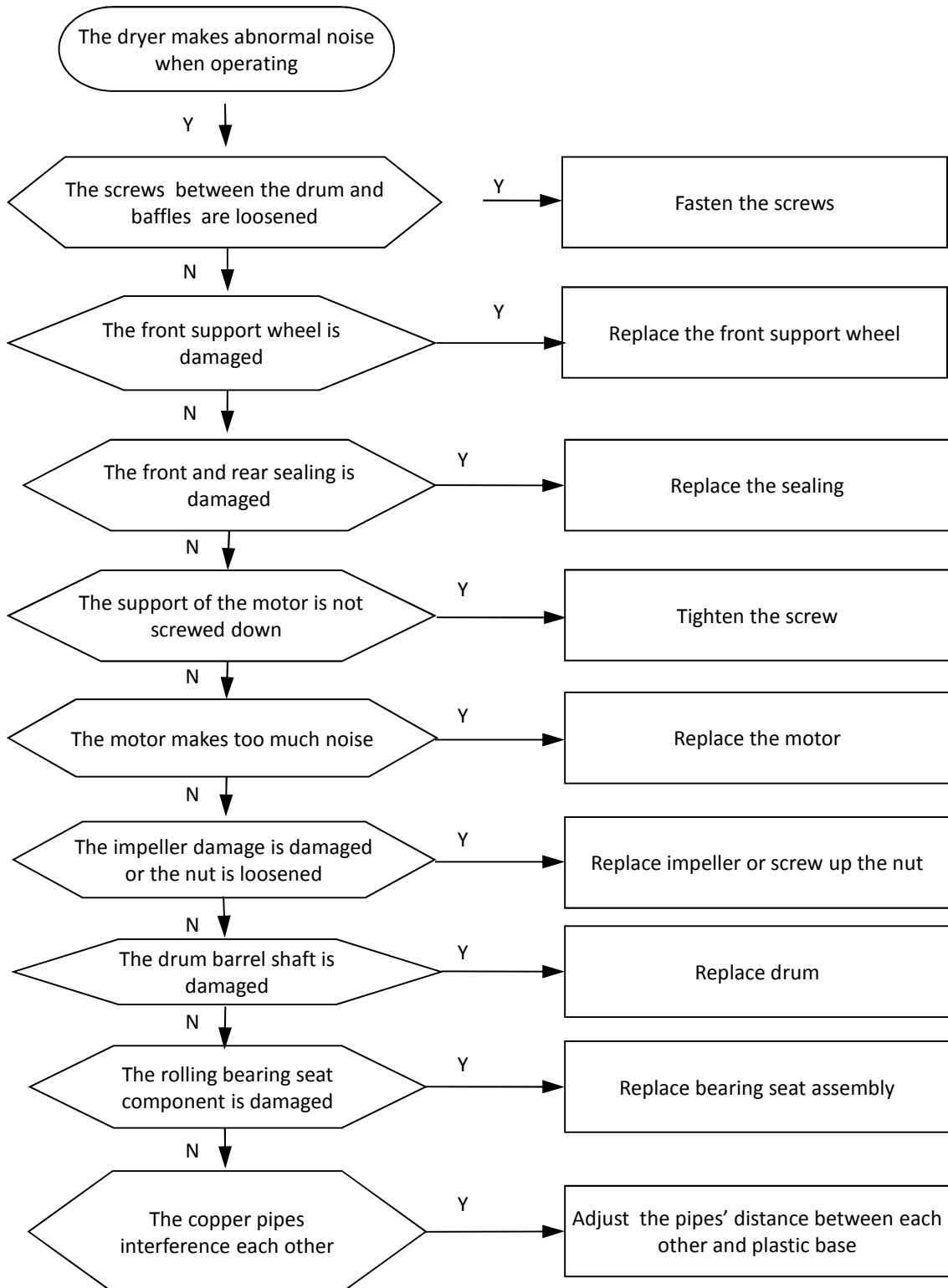

5.5 The dryer gives out abnormal smell when operating

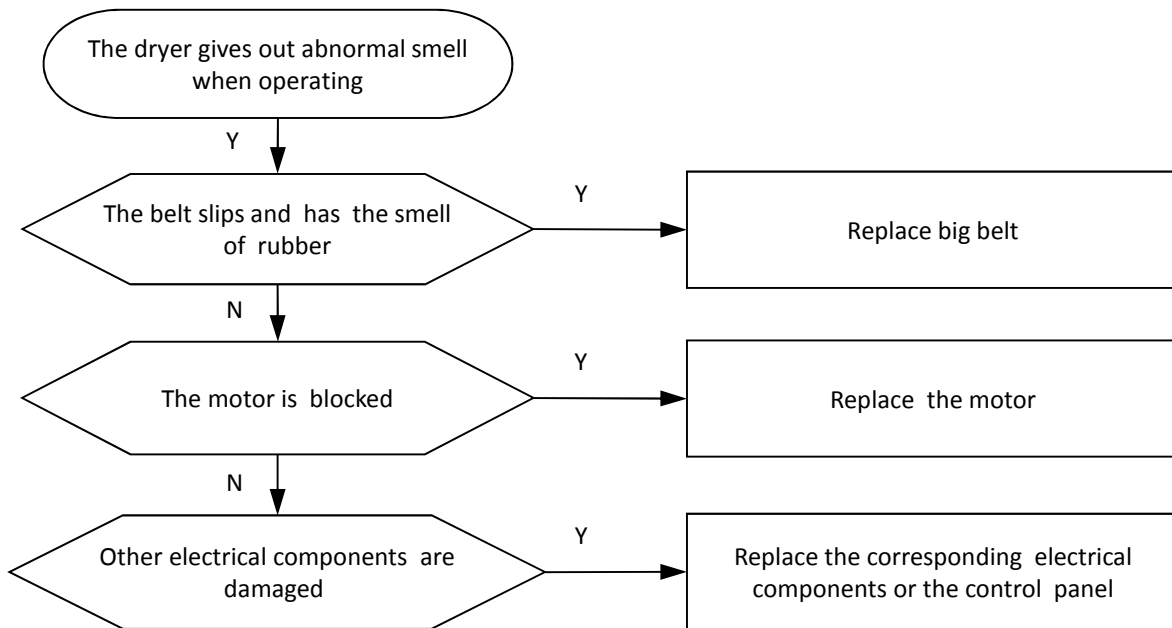

5.6 Dryer's 'Full' LED is lighting

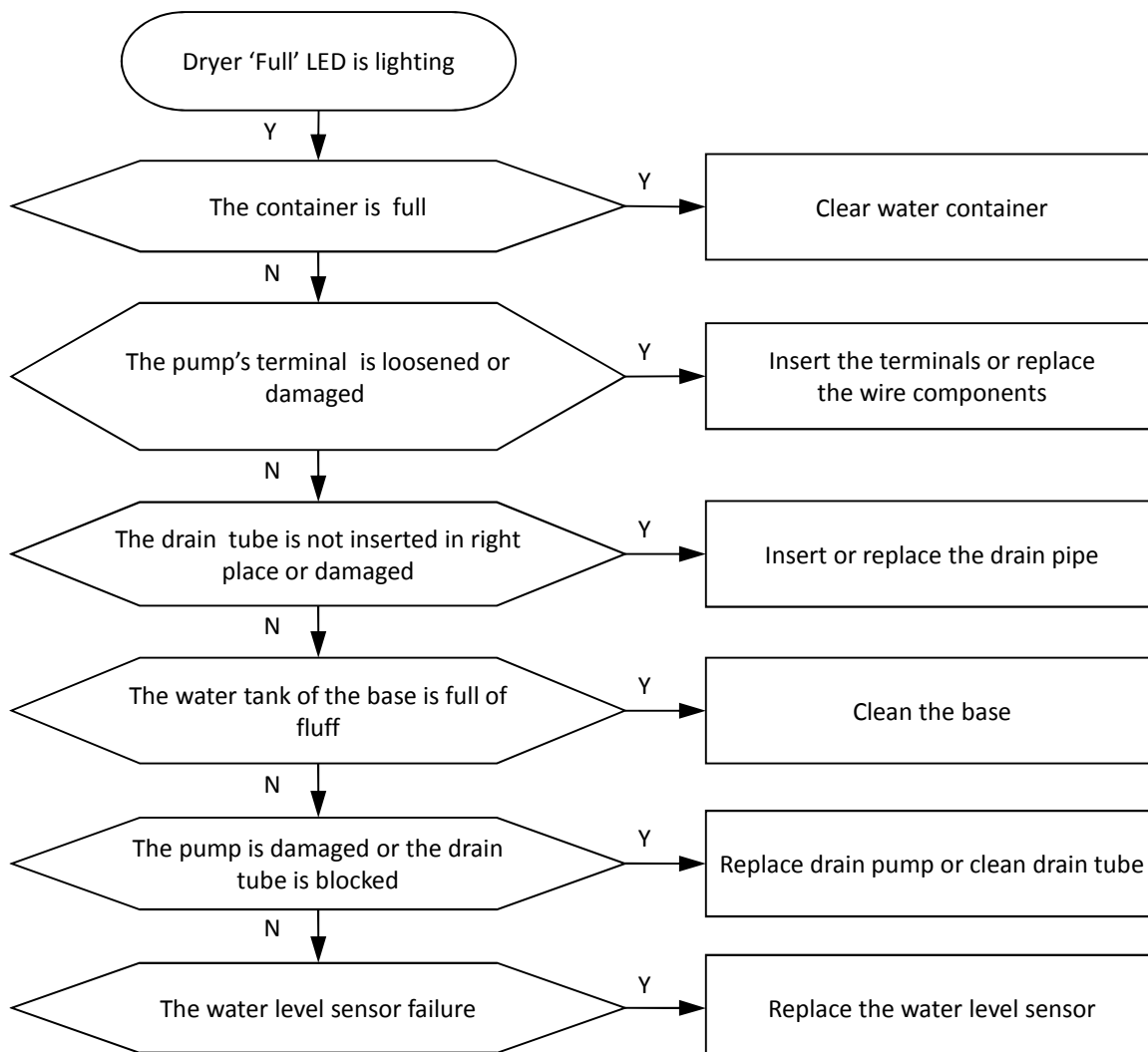

5.7 E32 LED is lighting after the cycle finished.

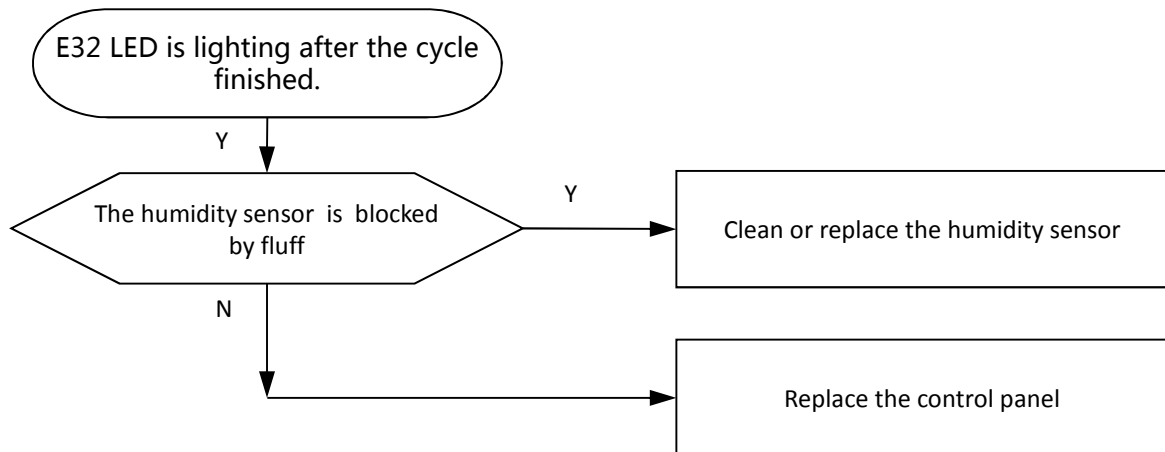

5.8 E33 LED is lighting

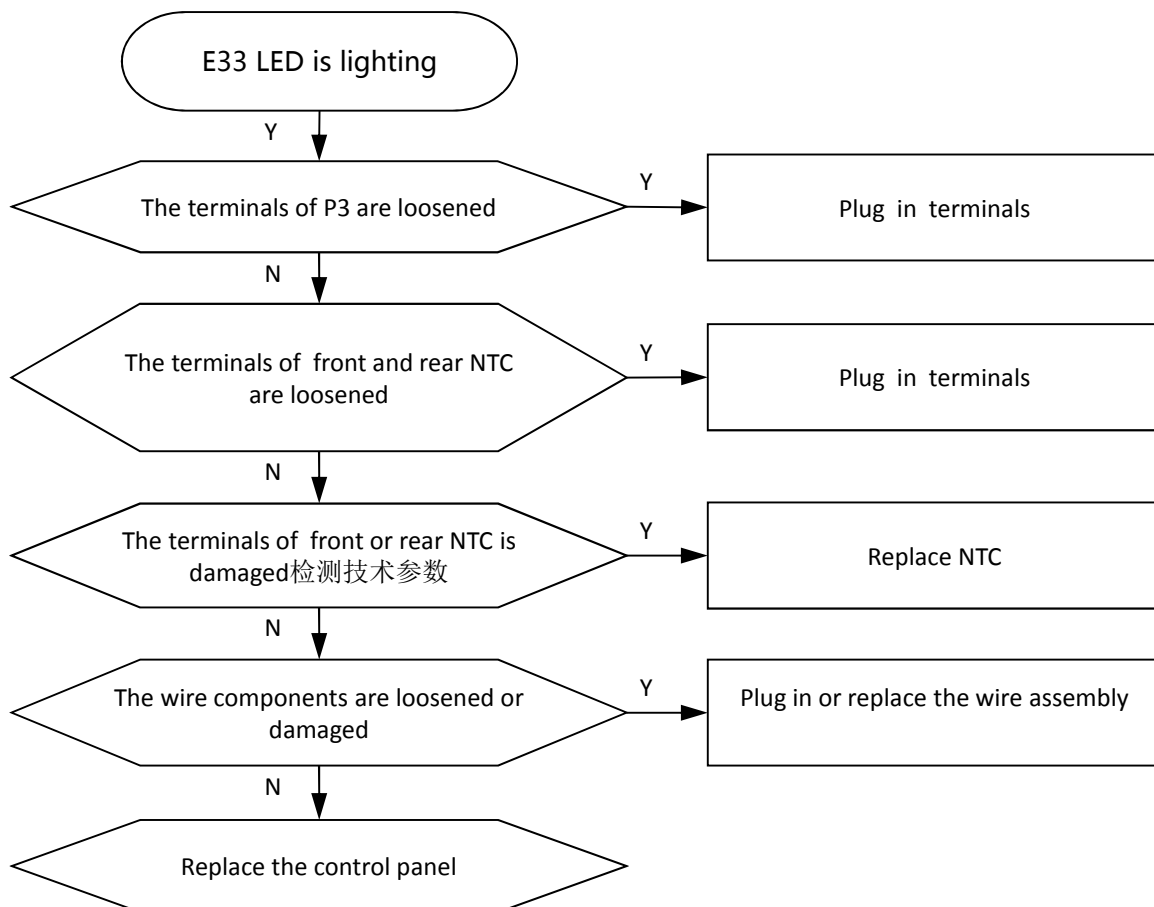

5.9 E50 LED is lighting after the cycle finished.

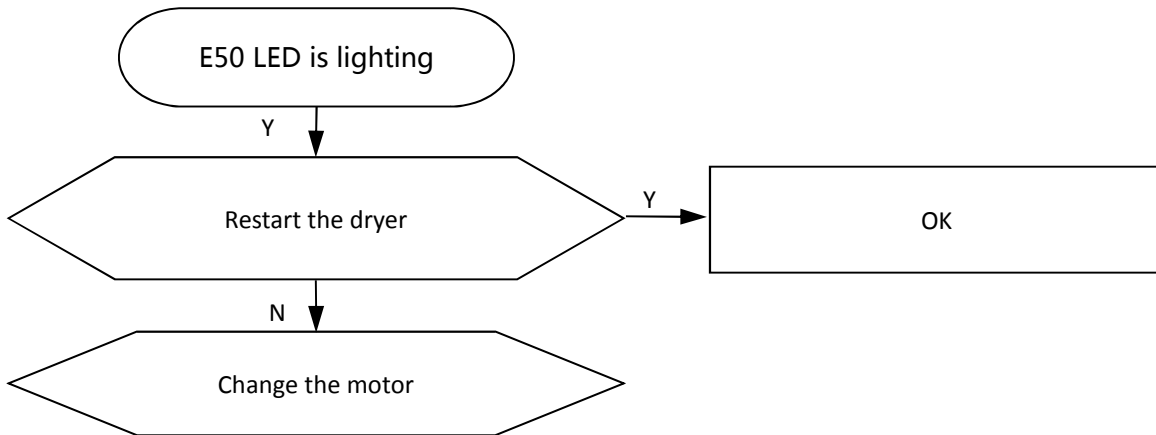

5.10 E64 LED is lighting after the cycle finished(only for BLDC model)

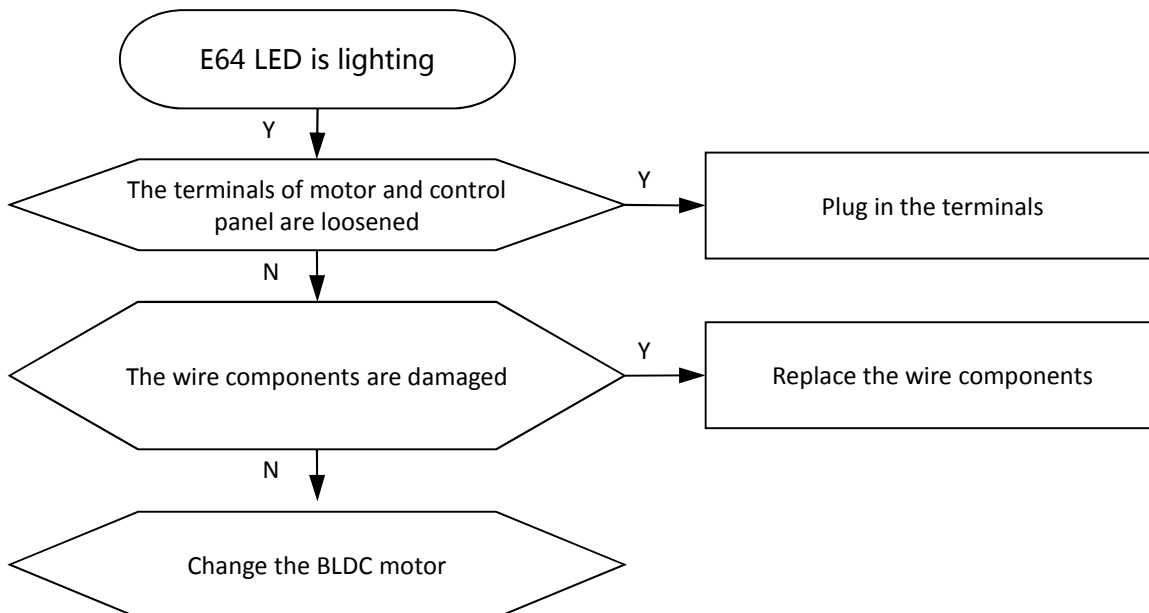

5.11 E82 LED is lighting .

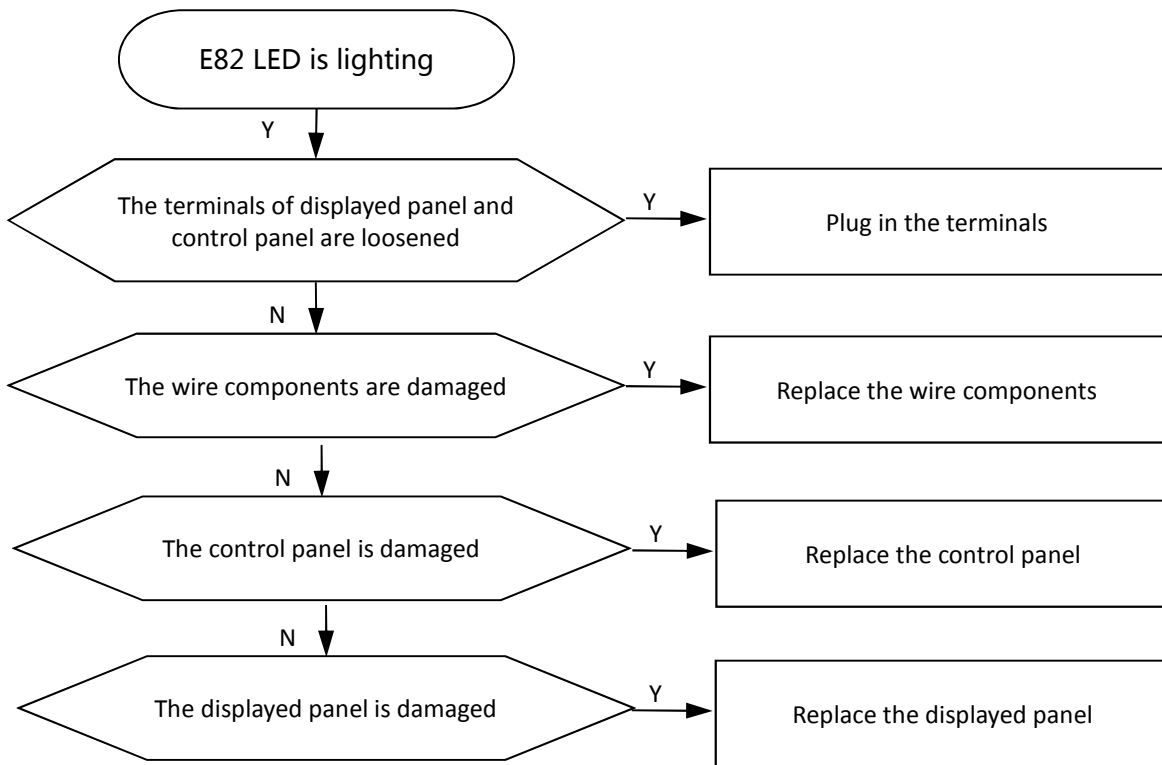

5.12 Heat pump system parts repair:

Warning : If the heat pump system parts need to be repaired , we suggest replacing with new machines rather than maintenance. The heat pump system parts include capillary , drier filter, connecting pipe, condenser, evaporator, compressor and etc.

Attention:

- 1, Must use special equipment which is only for HC-290 device, avoid mixed with other refrigerants.
- 2, Don't leave the heat pump system open for more than 30min. For the oil in compressor has very strong water absorbing capacity, pull out the rubber plug before using the compressor.
- 3, Must use special drier filter which is only for HC-290.
- 4, Ensure the maintenance area is clean ,open,well-ventilated and away from the open fire.

Operation step	Picture
<p>1,Take out the heat pump system and use exhaust plier to release refrigerant. Warning:Wear safety goggles and gloves .</p>	
<p>2,Vacuum pumping Warning:Before welding the HP system, vacuum first Vacuum pumping time is not less than 10 min.</p>	
<p>3,Welding position (Remove the parts that need to be replaced)</p>	
<p>4,Prepare new parts No matter which part of the HP system needs to be repaired,the discharge pipe and drier filter should be replaced.</p>	

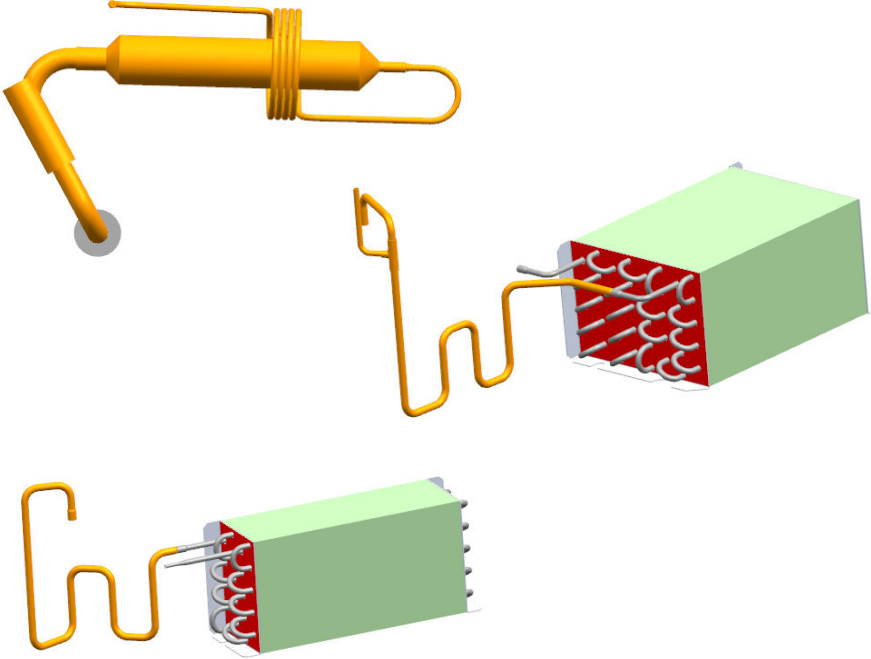
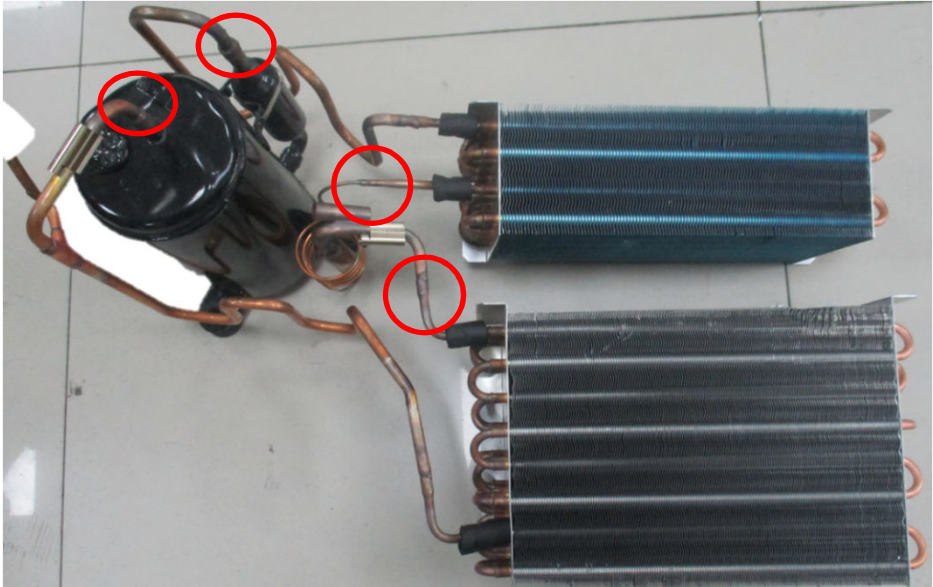
Operation step	Picture
<p>5,Weld capillary ,drier filter and connecting pipes, and heat exchangers.</p>	
<p>6,Weld the suction pipe and discharge pipe to compressor, weld the capillary and connecting pipe to heat exchangers.</p>	



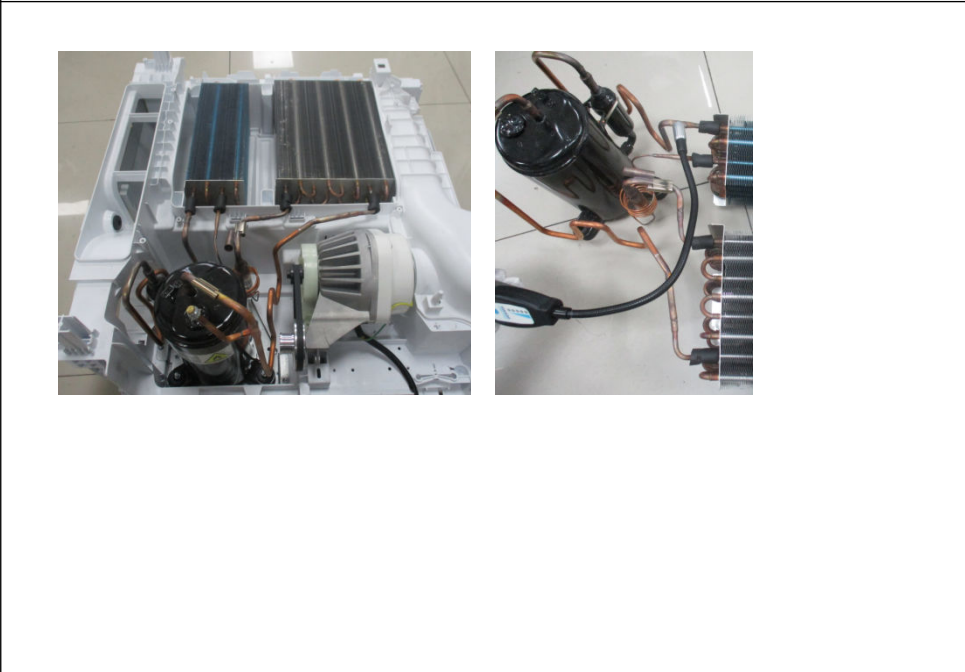





Operation step	Picture
<p>7, Vacuum pumping</p> <p>1, Connect high pressure connector to the charge pipe($\phi 6\text{mm}$),</p> <p>2, Connect the connector to the plug,</p> <p>3, Close V2 and V5 Valves, open V1, V3, and V4.</p> <p>4, Start the pump.</p> <p>Vacuum pumping time is not less than 60 min, and the pressure is maintaining for more than 10min, to ensure the vacuum degree of the HP system is less than 50Pa.</p>	

Operation step	Picture
<p>8, Fill refrigerant Use electronic scale with an accuracy of at least 0.5g to weigh the filling amount.</p>	<p>Type: R290 (HC-290) Quantity: check the name plate of the dryer</p>
<p>9, Seal the charge pipe</p> <ol style="list-style-type: none"> ① Seal the pipe 40mm below the charge pipe mouth with sealing plier. ② Drop the lokprep into the lokring stopper. ③ Put the lokring stopper on the charge pipe, and rotate it to distribute the lokprep evenly. ④ Connect pipe and lokring stopper with press plier. 	
<p>10, Tidy the pipes and leaking check.</p> <ol style="list-style-type: none"> ① Make sure the connecting pipes are not interference with each other and not impact the compressor, motor and other parts of the machine. ② Check all the weld points with leak detector. 	

6 Check Point of Electronic Components



Before repairing, use multimeter to judge circuit stand of fail.

No	Part	Picture	Test Description	parameters
1	Electric Filter		With a multimeter to test the connection at both ends of the N and L.	250VAC 50/60HZ, 12A
2	NTC		Measured across the NTC with a multimeter, the resistance line with RT table.	10°C 9.6±5%KΩ 15°C 7.6±5%KΩ 25°C 4.8±5%KΩ 30°C 3.9±5%KΩ
3	Capacitor		Tested capacitance value should be 20 ± 5% uF	20μF±5% 450VAC 50/60HZ
4	Drain Pump		Measure the ends of the pump with a multimeter . 800× (1 ± 10%) Ω (20 °C)	220-240V, 50HZ, 0.8m, 4L/min, 13W
5	Water Level Sensor		Conducting both ends with a multimeter test case, disconnect the float at the bottom of the float.	10mv-24vAC;10mv-200vDC ,10VA 10W, 10UA-1A(DC)
6	Door Switch		Conducting both ends with a multimeter test case, under normal disconnect, press on.	250V 16A
7	Motor Assembly	 		220-240V, 50Hz,150W, Copper wire, Class 155
8	Cooling fan		AC 220~240V~50/60HZ, 0.07/0.07A	220-240VAC, 50/60HZ

7 Service tools



M14

M10



General tools

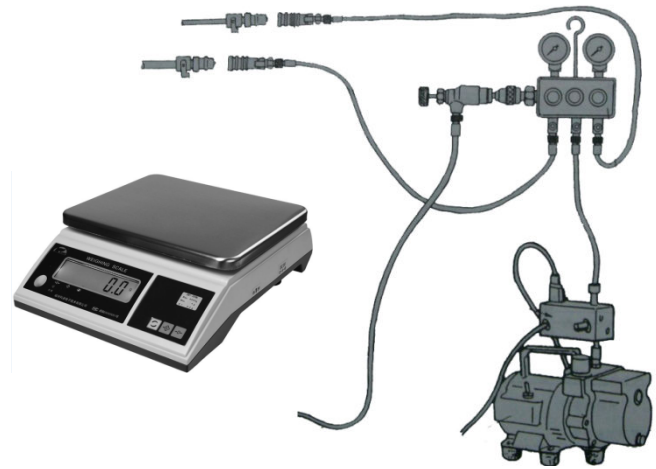

Press plier Sealing plier Exhaust plier Electronic scale Pressure gage Vacuum pump

Number	Tools	Use
1	General tools Cross head screwdriver, Pliers, Sleeves(M14 and M10)	Disassembly and assembly of structural parts
2	Press plier, Sealing plier, Exhaust plier	Release refrigerant Vacuum pumping Fill refrigerant
3	Vacuum pump, welding torch, exhaust plier, sealing plier, press plier, leak detector, electronic scale, butane and oxygen carrier and so on.	Weld the pipes Vacuum and charge Leak check

Machine function description, program description, the whole detailed parameter table, fault codes, etc. Please refer to the instructions.

Note: The schedule for the reference value.

The end!